



**TRANE®**

Installation  
Operation  
Maintenance

---

# **Energy Wheels**

**for M-Series Climate Changer™ Air  
Handlers**

---

February 2004

**CLCH-SVX02C-EN**



# General Information

Use this manual to install, startup, operate, and maintain the energy wheel module for M-Series Climate Changer™ air handlers. Carefully review the procedures discussed in this manual to minimize installation and startup difficulties. The startup and adjustment procedures discussed in this manual should be done by *qualified, experienced* HVAC technicians.

Your personal safety and the proper operation of this machine depend upon the strict observance of these precautions.

## Warnings and Cautions

**NOTICE:** Warnings and Cautions appear at appropriate sections throughout this literature. Read these carefully.

 **WARNING:** Indicates a potentially hazardous situation which, if not avoided, could result in death or serious injury.

 **CAUTION:** Indicates a potentially hazardous situation which, if not avoided, may result in minor or moderate injury. It may also be used to alert against unsafe practices.

**CAUTION:** Indicates a situation that may result in equipment or property-damage only accidents.



# Contents

<b>Introduction</b>	
General Information .....	2
<b>Description</b>	
How the Modules Arrive at the Job Site.....	4
Receiving Inspection.....	5
Storage .....	5
Contractors' Responsibilities .....	5
<b>Installation</b>	
Service Clearance .....	6
Rigging/Lifting.....	6
Assembly.....	7
Actuator Installation .....	7
Module-to-Module Assembly .....	8
<b>Wiring</b>	
Energy Wheel Motor.....	9
Options .....	9
<b>Operation</b>	
Energy Wheel Startup .....	10
<b>Routine Maintenance</b>	
Cleaning the Energy Wheel.....	11
Segment Removal/Replacement .....	11
Cleaning the Energy Wheel Motor .....	14
Cleaning the Module .....	15
Bearing and Motor Lubrication.....	15
Energy Wheel Drive Belt Adjustment.....	15
Air Filters .....	15
<b>Service and Repair</b>	
Bearing/Drive Belt Replacement.....	16
Seal Adjustment.....	17
Drive Motor and Pulley Replacement .....	18
<b>Troubleshooting</b>	
Probable Causes/Actions.....	19

## Description

The M-Series Climate Changer™ air handler energy wheel module is an efficient, low-maintenance energy recovery device. It is an integral part of an entire air-handling system. The module consists of the energy wheel cassette assembly and access on either side of the energy wheel.

All energy wheel modules feature removable individual segments for cleaning and replacement.

M-Series air handlers sizes 3 to 8 are designed for the energy wheel cassette to slide out of the module for changing bearings, motors, and belts. A removable panel is provided on both sides for this purpose (see Figure 1).

**Figure 1. M-Series air handler energy wheel module with removable access panel, size 3 to 8**



The energy wheel cassette in unit sizes 10 to 50 is permanently installed in the module. Four access doors are provided for cleaning and maintenance (see Figure 2).

**Figure 2. M-Series air handler energy wheel module with four access doors, sizes 10 to 50**



Optional air bypass dampers may ship with the module. If ordered, these dampers are factory-installed in the same bulkhead wall as the energy wheel cassette. Optional actuators may be attached to the dampers.

### How the Module Arrives at the Job Site

**No Base Rail Option** If the optional base rail was not ordered, the energy wheel module will arrive mounted to a wood skid. The module is held on to the skid with steel bands and/or screws. Leave the module mounted to the wood skid until it is ready to install in the equipment room to help protect it from damage during rigging and handling. Note: The mounting legs will be pre-installed to the module and attached to the skid. Take care that the legs are not discarded. Refer to the instruction sheets in the ship-with kit.

**Base Rail Option** The base rail is an optional steel channel frame that is used to elevate the module off the floor or to suspend it from the ceiling. If ordered, the base rail is attached for unit sizes 3 to 40. The energy wheel module will arrive mounted on the base rail. For unit size 50, the base rail is shipped banded to a separate skid for field installation. If separate, wood skid boards are attached to the bottom of the base channels. Leave the wood skid boards attached to the base rail until it is ready to install in the equipment room to protect it from damage during rigging and handling.

**Amowrap® Covering** The large openings of the module are protected by Amowrap reinforced plastic covering. The Amowrap covering is held on to the module with a wood frame and sheet metal screws. Leave the Amowrap covering attached to the module until it is ready to install in the equipment room to prevent debris from entering the module.

**Hardware Kit** Hardware kits ship inside the module. The kits contain gasketing, brackets, and screws, which are used when fastening the module to the air handler. Keep the hardware kit with the energy wheel module until it is ready to install in the equipment room.

**Access Doors** Access doors are secured for shipment with a bracket. Remove and discard bracket when the module arrives.



### Receiving Inspection

Upon receipt of the module, inspect it for damage that may have occurred during shipment. *Report damage immediately to the freight company and make a note on the shipping tally sheet.*

- Remove the access door shipping clamps (flat brackets) and check for internal, hidden damage. *Concealed damage must be reported within 15 days of receipt.* Trane is not responsible for shipping damage.
- Locate the bags containing the hardware kits.
- Examine the energy wheel motor, drive, and energy transfer segments for damage.
- Cut the banding loose from the skid. Do not remove the module from the skid at this time.
- Manually rotate the energy wheel to ensure free movement of the bearings and drive.

### Storage

Trane recommends indoor storage of the module. If outdoor storage is necessary, select a solid, well-drained area. Concrete or black top surfaces are recommended. If concrete or black top is not available, set the module on wood timbers to prevent dirt, mud, snow, etc. from getting into the module. Cover the module with a canvas tarp. Covering the module with clear or black plastic sheeting is *not* recommended as this material traps condensed moisture, which can cause equipment damage due to rust and corrosion. If equipped with a factory-installed starter, it will be covered with plastic during shipping. The plastic covering must be removed before outdoor storage. *Trane warranty does not cover equipment damage due to negligence during storage.*

### Contractors' Responsibilities

#### Installing Contractor

- Unpack the module and remove the skid or skid boards.
- Remove the Amowrap protective covering.
- Rig and/or move the module into the equipment room. The contractor must provide slings, spreader bars, clevis hooks, pins, etc., for rigging.
- Provide a reasonably level floor, pad, or ceiling suspension system for the air handler.
- Assemble the energy wheel module to the air-handling system.

### Electrical and/or Controls Contractor

- Provide high voltage power to the energy wheel. For voltage requirements, see Table 3 in "Wiring" on page 9.
- Provide and install a starter or starting contactor, disconnect, fuses, etc. (as required by local codes) for the energy wheel motor if a factory-installed starter is not provided.
- Provide, install, and connect damper actuators if the module is equipped with optional air bypass dampers less the actuators.
- Provide, install, and connect temperature sensors for energy wheel controls if the module is not equipped with factory-installed sensors.
- Provide, install, and connect required control devices for energy wheel controls if the module is not equipped with factory-installed devices, or connect to factory-installed devices that were not ordered factory-wired.

# Installation

## **⚠ WARNING** Improper Unit Lift!

Do not lift the unit from top! Lift from lifting lugs only located at bottom of unit. Test lift unit approximately 24 inches to verify proper center of gravity lift point. To avoid dropping of unit, reposition lifting point if unit is not level. Failure to properly lift unit could result in death or serious injury or possible equipment or property-only damage.

## **⚠ WARNING** Heavy Objects!

Follow good lifting practices before lifting the unit, such as estimating center of gravity and test lifting the unit to check for balance and stability. Each of the cables (chains or slings) used to lift the unit must be capable of supporting the entire weight of the unit. Lifting cables (chains or slings) may not be of the same length. Adjust as necessary for even unit lift. Other lifting arrangements could cause equipment or property-only damage. Failure to properly lift unit could result in death or serious injury.

## Service Clearance Recommendations

For unit sizes 3 to 8, locate the module to allow removal of the energy wheel cassette through the access panel. Typically, the minimum clearance is equal to the module width plus 12 inches.

For unit sizes 10 to 50, locate the module to allow all access doors to open fully. Make provisions for temporary access on either side of the module for complete removal of the cassette/wheel frame. This would be required if complete replacement of the entire cassette/wheel assembly were needed. The minimum recommended clearance for this is equal to the module width plus 12 inches.

Local electrical code clearance requirements must be considered when a factory-installed starter is provided.

## Rigging/Lifting

Refer to the M-Series air handler installation and maintenance manual, CLCH-SVX03B-EN, for instructions on equipment rigging and lifting. This manual ships inside the air handler fan module.

## Module Weights and Dimensions

Refer to Trane catalog CLCH-PRC006-EN or equipment submittals for module weights and dimensions.

## Suspending Modules with Base Rails

When suspending an energy wheel module, it is required to suspend it from all lifting lugs on both the energy wheel module and any adjoining modules (see Figure 3).

Figure 3. Use all lifting lugs when suspending energy wheel modules

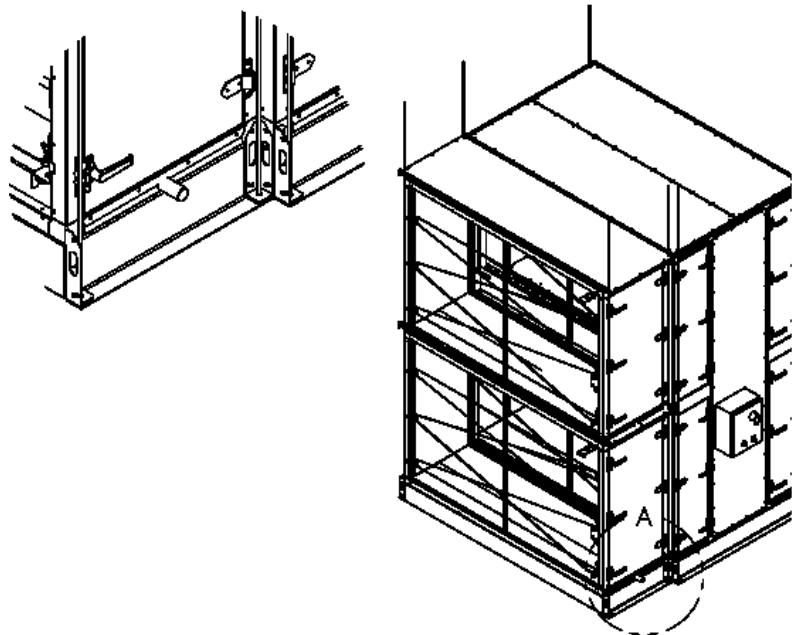

## Assembly

Refer to the design engineer's plans and submittals for the location of the energy wheel module in the air handler. The energy wheel module will also be labeled with airflow direction markings. Final assembly of the air handler should be done at the installation site. Refer to the M-Series air handler installation and maintenance manual, CLCH-SVX03B-EN, which ships inside the fan module, for further instructions on equipment assembly.

## Unattached Base Rails

When energy wheel modules are shipped with unattached base rails, refer to M-Series air handler installation and maintenance manual, CLCH-SVX03B-EN under installation instructions.

## Actuator Installation

If the module is equipped with optional air bypass dampers and/or recirculating dampers, and the actuators are field-installed, refer to Table 1 and Table 2 for the actuator sizing requirements.

**Table 1. Air Bypass Damper Torque Requirements (pound-inch) per damper**

Wheel CFM	900/1500	3000	4000	5000	6000	7000	8500	10500	12500	15000	17500	20000	25000
Torque	20	20	20	20	20	38	42	30	73	85	96	116	130

**Table 2. Recirculating damper torque requirements (pound-inch) per damper**

Unit Size	3	6	8	10	12	14	17	21	25	30	35	40	50
Torque	20	20	20	30	31	34	75	77	79	94	99	114	127

## Module-to-Module Assembly

### Special Leg Assembly

For sizes 3 to 30 with skid, special leg assembly and module-to-module installation (see Figure 4):

- Remove existing module leg and saddle bracket from adjoining module.
- Replace with special 4-inch or 6-inch leg for modules mounting to the energy wheel.
- Remove saddle bracket from energy wheel module.
- Reattach the existing mounting leg on the energy wheel module.
- Follow instructions from ship-with kits.

**Figure 4. Sizes 3 to 30 with skid, special leg assembly and module-to-module installation**

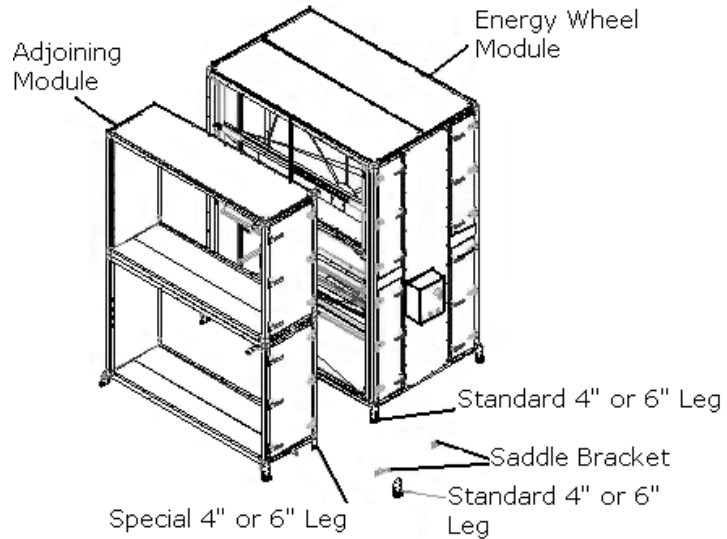

### Lifting Lug Removal

For sizes 35 to 50 with skid, special lifting lug removal and module-to-module installation (see Figure 5):

- Remove saddle bracket from adjoining module.
- Reattach existing mounting leg so that the edge nearest the energy wheel module is flush with the side of the adjoining module. See Mounting Leg Detail in Figure 5.
- Remove saddle bracket and special lifting lugs from energy wheel module.
- Reattach existing mounting leg on the energy wheel module.
- Follow instructions from ship-with kit.

**Figure 5. Size 35 to 50 with skid, special lifting lug removal and module-to-module installation**

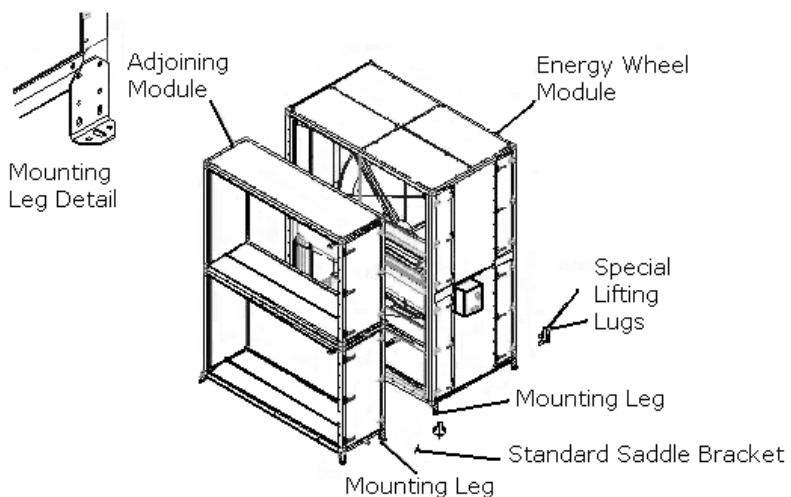

# Wiring

## CAUTION Do Not Install VFDs

Do not install a variable-frequency drives (VFDs) to control the energy wheel speed. This may result in failure of the energy wheel motor.

## CAUTION Factory-Installed Wiring

Take care when penetrating the unit casing. Factory wiring may be routed in the side panels of the module. (See Figure 6). They will be labeled.

**Figure 6. Energy wheel modules may have factory-installed ribbon cables attached inside. Take care when penetrating the unit casing.**



## Energy Wheel Motor

Refer to Table 3 for the energy wheel voltage and amperage requirements. Refer to the factory sales order to determine the energy wheel size.

If not factory-installed, the electrical contractor must penetrate the unit casing, provide and install a starter or starting contactor, disconnect, fuses, etc., as required by local codes, for the energy wheel motor. Do not install a variable frequency drive (VFD) to control the energy wheel speed. This may result in failure of the energy wheel motor.

**Table 3. Energy wheel voltage and amperage requirements**

Wheel Size (nominal cfm)	Motor hp	Motor voltage/phase	Motor Hz	Motor Amperage
900, 1500	n/a	208-230 volt, single-phase	50/60	0.3
3,000-5,000	1/6 hp	200/208-230 volt, single-phase	50/60	1.2
3,000-5,000	1/6 hp	200-230 volt, three-phase	60	0.80-0.75
3,000-5,000	1/6 hp	460 volt, three-phase	60	0.38
3,000-5,000	1/6 hp	575 volt, three-phase	60	0.3
6,000-15,000	1/4 hp	200-230 volt, three-phase	60	2.3-2.5
6,000-15,000	1/4 hp	460 volt, three-phase	60	1.2
6,000-15,000	1/3 hp	575 volt, three-phase	60	1.4
17,500-25,000	1/3 hp	200-230 volt, three-phase	60	3.4
17,500-25,000	1/3 hp	460 volt, three-phase	60	1.7
17,500-25,000	1/3 hp	575 volt, three-phase	60	1.4

## Optional Damper Actuators

Each actuator requires 24 Vac supply power and wiring for the 2-10 Vdc control signal. This wiring should be sized and installed as required per national and local electrical codes.

## Optional Air Temperature Sensors

If not factory-wired, connection to the air temperature sensors is made by penetrating through the side of the module wall and making electrical connections to the temperature sensor. Nominal resistance of these sensors is 1,000 ohms at 32 degrees F (0 degrees C). The sensor is a thermistor with a platinum 375 resistance curve. This wiring should be sized and installed as required per national and local electrical codes.

## Optional Exhaust Air Pressure Differential Switch

If not factory-installed, connection to the exhaust air pressure differential switch must be made inside the module. This is a double-pole,

single-throw (DPST) switch with a normally open and normally closed contact. Both poles are rated at 120v, 1/6 hp. This wiring should be sized and installed as required per national and local electrical codes.

## Optional Dirty Filter Switch

If not factory-installed, connection to the dirty filter switch must be made inside the module. This is a double-pole, single-throw (DPST) switch with a normally open and normally closed contact. Both poles are rated at 120v, 1/6 hp. This wiring should be sized and installed as required per national and local electrical codes.

## Optional Exhaust Air Frost Control Temperature Sensor

If not factory-installed, connection to the exhaust air frost control temperature sensor must be made inside the module. The sensor is a thermistor with a nominal resistance of 1,000 ohm at 70 degrees F (21 degrees C) and a linear resistance curve. This wiring should be sized and installed as required per national and local electrical codes.

# Operation

## WARNING Do Not Exceed Max Airflow!

Do not exceed the maximum rated airflow for the wheel. The pressure drop across the wheel is not to exceed 1.25 inches w.g.

## ⚠ WARNING Toxic Hazards!

Do not use an energy wheel in an application where the exhaust air is contaminated with harmful toxins or biohazards, which could result in death or serious injury.

## ⚠ WARNING Hazardous Voltage, Rotating Parts!

Disconnect all electrical power, including remote disconnects before servicing. Follow proper lockout/tagout procedures to ensure the power can not be inadvertently energized. Secure drive sheaves to ensure rotor cannot freewheel. Failure to disconnect power before servicing could result in death or serious injury. Keep hands away from the rotating wheel! Contact with the rotating wheel could cause physical injury.

## Energy Wheel Startup

1. Set diameter seals. See "Seal Adjustment" on page 17.
2. Turn the energy wheel clockwise (as viewed from the pulley side) by hand to verify that the wheel turns freely through its full rotation.
3. Confirm that all wheel segments are fully engaged in the wheel frame and that segment retainers are completely fastened. (see Figure 7).
4. With hands and objects away from moving parts, activate the wheel and confirm the wheel rotation. The correct rotation direction is clockwise as viewed from the pulley side.
5. Start and stop the wheel several times to confirm seal adjustment and proper belt tracking on the wheel rim. The correct belt tracking is approximately a quarter inch from the outer edge of the rim. (see Figure 8).
6. If the wheel has difficulty starting, turn off the power and inspect for excessive interference between the wheel surface and the four diameter seals. To correct, loosen the diameter seal adjusting screws and back the diameter seals away from the surface of the wheel. Apply power to confirm that the wheel rotates freely. Readjust and tighten the seals according to instructions in "Seal Adjustment" on page 17.
7. Damper actuators (if so equipped): Stroke the actuators to observe full open and full closure of dampers. Adjust the actuator and/or linkage to prevent "over-stroking" so excessive pressure is not placed on the damper at the full open or full closed position.

**Figure 7. Completely fasten segment retainers**

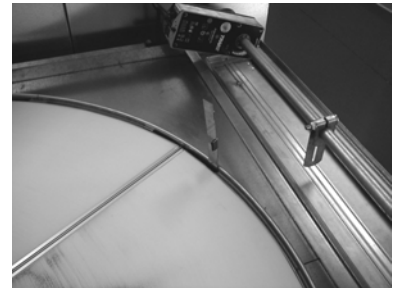

**Figure 8. Confirm proper belt tracking on the wheel rim**

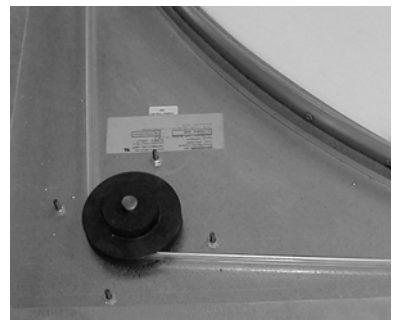



# Routine Maintenance

## **⚠ WARNING** **Hazardous Voltage!**

Disconnect all electric power, including remote disconnects before servicing. Follow proper lockout/tagout procedures to ensure the power can not be inadvertently energized. Failure to disconnect power before servicing could result in death or serious injury.

## **⚠ WARNING** **Keep Hands Away!**

Always keep hands away from the bearing support beam when installing or removing segments. Failure to do so could result in serious injury.

## **CAUTION!** **Cleaners And Solvents**

Do not use acid based cleaners, aromatic solvents, steam, or temperatures in excess of 170°F. Doing so may cause damage to the wheel!

## **CAUTION!** **Keep Wheel Clean**

Accumulated dirt and debris may result in reduced airflow and/or increased pressure drop across the energy wheel. Increased pressure drop can result in permanent damage to the energy wheel or module.

## **Cleaning the Energy Wheel**

Disconnect all electrical power, then use a vacuum or brush to remove accumulated material from the face of the wheel. Examine the energy wheel monthly for material build-up on the wheel.

If more aggressive cleaning is needed, segment removal may be required.

1. Wash the segments or the wheel in a five-percent solution of non-acid-base coil cleaner (part no. CHM00021 at your local Trane parts center) or in an alkaline detergent and warm water.
2. Soak the segments in the solution until grease, oil, and tar deposits are loosened.
3. Before removing the cleaner, rapidly run your fingers across the surface of the segments to separate the polymer strips for better cleaning actions.
4. Rinse the dirty solution from the segments and remove excess water before re-installing the segments in the wheel. Note that some permanent staining of the desiccant may remain but is not harmful to performance.

## **Cleaning Frequency**

In reasonably clean office or school buildings, cleaning with coil cleaner solution may not be required for several years. If the energy wheel is exposed to air streams containing, for example, high levels of occupant tobacco smoke, cooking facility exhaust air, or oil-based aerosols found in machine shop areas, annual cleaning may be required to remove these contaminants and restore performance.

High maintenance applications like these may benefit from keeping a spare set of clean segments on hand. This allows for rapid change-out of clean segments with minimal downtime. The dirty segments can then be cleaned at a convenient time.

## **Segment Removal/Replacement**

### **Segment Removal (for wheel cfm 900-15,000)**

For unit sizes 3 to 8, the energy wheel module is equipped with only *one* access panel and the entire energy wheel cassette slides out through the door for maintenance. For unit sizes 10 to 50, the energy wheel module is equipped with *four* access doors and the wheel segments are removable. Wheel segments are secured to the wheel frame by a segment retainer, which pivots on the wheel rim and is held in place by a segment retaining catch.

1. Disconnect all electrical power.
2. Unlock the two segment retainer brackets, one on each side of the selected segment opening (see Figure 9).
3. Remove the segment from the wheel frame. It may be necessary to *gently* pry the segment out of the wheel with a screwdriver.
4. Pull the segment up and out of the wheel frame (see Figure 10).
5. Close any open segment retainers prior to rotating the wheel. Failure to close any retainer may damage the retainer, seals, or segments.
6. Slowly rotate the wheel by hand 180 degrees and repeat the process to remove the second segment.
7. Rotate the wheel 90 degrees by hand and remove the third segment.

8. Rotate the wheel 180 degrees by hand and remove the fourth segment. Rotating the wheel in this manner keeps the wheel balanced while removing the segments.
9. Continue this procedure to remove all the segments.

### Segment Replacement (for wheel cfm 900-15,000)

#### **⚠ WARNING** **Hazardous Voltage!**

**Disconnect all electric power, including remote disconnects before servicing. Follow proper lockout/tagout procedures to ensure the power can not be inadvertently energized. Failure to disconnect power before servicing could result in death or serious injury.**

1. Disconnect all electrical power.
2. Unlock the two segment retainers, one for each side of the selected segment opening (see Figure 9).
3. With the embedded stiffener facing the motor side, insert the nose of the segment between the hub plates (see Figure 11).
4. Holding the segment by the two outer corners, press the segment toward the center of the wheel and inward against the spoke flanges. If hand pressure does not fully seat the segment, insert the flat tip of a screwdriver between the wheel rim and outer corners of the segment and apply downward force while guiding the segment into place.
5. Close and latch each segment retainer under the segment retaining catch.
6. Slowly rotate the wheel 180 degrees by hand. Install the

second segment opposite the first for counterbalance.

7. Rotate the two installed segments 90 degrees by hand to balance the wheel while the third segment is installed.
8. Rotate the wheel 180 degrees by hand to install the fourth segment opposite the third.
9. Repeat this sequence with the remaining four segments.

Replacing the segments with a spare set can be accomplished more quickly. Remove the dirty segment, replace it with a clean segment, then move to the next segment. The 180/90/180-degree rotation procedure is not necessary.

**Figure 11. Insert nose of segment between hub plates to install**



**Figure 9. Unlock the segment retainers**



**Figure 10. Pull the segment up and out of the wheel frame to remove**

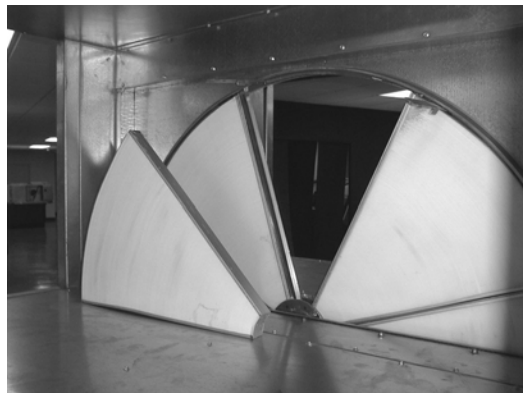

### Segment Removal (for wheel cfm 17,500 and higher)

For energy wheel applications requiring 17,500 cfm and higher, wheel segments with satellite sections are used (see Figure 12).

### Removal Procedure for Outer Segments

#### **⚠ WARNING** **Hazardous Voltage!**

**Disconnect all electric power, including remote disconnects before servicing. Follow proper lockout/tagout procedures to ensure the power can not be inadvertently energized. Failure to disconnect power before servicing could result in death or serious injury.**

*Note: Install and remove all segments at location indicated by arrow in Figure 12.*

1. Disconnect all electrical power.
2. Align outer segment with wheel drive pulley. Secure pulley and belt with vise grip to prevent rotation (see Figure 13).
3. Insert flat tipped screwdriver between rim and segment retainer latch. Rotate screwdriver to release latch from under catch.
4. Rotate latch 90 degrees from rim. Remove forked segment retainers.
5. Insert screwdriver tip between corners of segment and spoke. Gently pry ends of segment part way out. Grasp one end of segment and lift straight out.
6. Remove vise grip. Repeat steps 1 through 3 for each segment in the order shown in Figure 12.

### Removal Procedure for Inner Segments

Remove inner segments in the order shown in Figure 12 as follows:

1. Align inner segment with wheel drive pulley. Secure pulley and belt with vise grip to prevent rotation (see Figure 13).
2. Support segment with one hand while removing 1/4-20 flat head retaining screw in hub with 5/32 inch Allen wrench.
3. With weight of segment resting on lower spoke, carefully slide segment out from between hub plates.
4. Being careful to balance segment on lower spoke with one hand, grasp nose of segment with other hand and remove from wheel.
5. Reinsert 1/4-20 screws in segment nose bracket to avoid loss.
6. Remove vise grip. Repeat steps 1 through 5 for each segment in the order shown in Figure 12.

**Figure 12. Install and remove segments in the order shown**

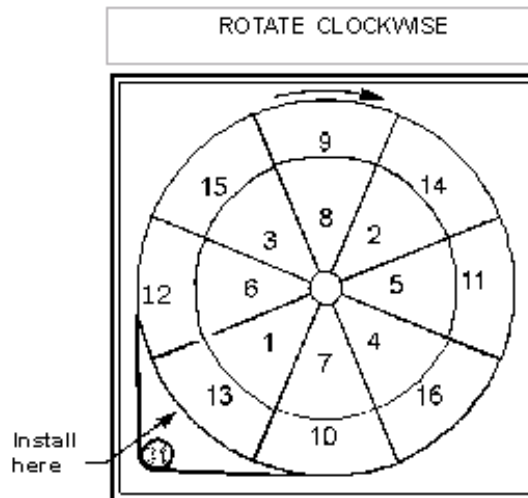

**Figure 13. Secure pulley and belt with vise grip to prevent wheel rotation.**



## Segment Replacement (for wheel cfm 17,500 and higher)

### Installation Procedure for Inner Segments

Note: Install and remove all segments at location indicated by arrow in Figure 12.

1. Rotate the wheel clockwise to align the center of a spoke opening with the pulley. Secure pulley and belt with vise grip to prevent wheel rotation (see Figure 13).
2. Remove 1/4-20 flat head screw from segment nose bracket.
3. Center and rest segment on lower spoke. Slide segment on spoke until nose bracket contacts stop in hub plate. Insert screw and tighten until screw is firmly seated (see Figure 14).
4. Holding wheel to prevent rotation, remove vise grip. Rotate wheel clockwise to install segments in the order shown in Figure 12.
5. Secure pulley. Repeat steps 2 through 4 until all inner segments are installed.

### Installation Procedure for Outer Segments

1. Align segment opening with pulley. Secure pulley and belt with vise grip to prevent rotation (see Figure 13).
2. Rotate outer segment retainer latch, located at end of spokes, 90 degrees from rim and remove two forked outer segment retainers.
3. Install outer segment by starting lower end in position and pressing straight in against four

corners. Sharp rap with heel of hand will assist entry when needed (see Figure 15). Note: Only reinstall segment retainer between adjacent installed segments.

4. Rotate both retainer latches to closed position to prevent interference with bearing support beam while rotating wheel by hand.
5. Repeat steps 1 through 4 in the order shown in Figure 12 until all outer segments are in place. Make certain all retainer latches are latched in place under catch

**Figure 14. Slide segment on spoke until contacts stop in hub plate.**



**Figure 15. Install outer segment by starting lower end in position and pressing straight in**



## Cleaning the Energy Wheel Motor

### **WARNING** **Hazardous Voltage!**

**Disconnect all electric power, including remote disconnects before servicing. Follow proper lockout/tagout procedures to ensure the power can not be inadvertently energized. Failure to disconnect power before servicing could result in death or serious injury.**

Disconnect all electrical power, then use a vacuum cleaner and brush to remove accumulated material from the energy wheel motor. The use of spray aerosol cleaners is not recommended. Examine the motor monthly for debris accumulation.

## Cleaning the Module

1. Disconnect all electrical power.
2. Use a vacuum cleaner to remove dust and debris from the module surfaces.
3. If needed, use a detergent solution to remove grease, oil, or other stubborn deposits from module surfaces. Follow the manufacturer's instructions regarding use of the product.
4. Rinse any cleaning product thoroughly from the module walls. The use of a water stream from a garden hose or high pressure washer is *not* recommended. Saturation of the wall panel insulation with potential microbial growth or damage to the energy wheel could occur.
5. Examine the module monthly for material build-up on the wall surfaces.

## Bearing and Motor Lubrication

The wheel drive motor and wheel support shaft bearings are permanently lubricated and no further lubrication is necessary.

## Energy Wheel Drive Belt Adjustment

The drive belt is a urethane stretch belt designed to provide constant tension throughout the life of the belt. No periodic adjustment is required. Inspect the belt annually for proper tracking and tension. A properly tensioned belt will turn the wheel immediately, with no visible slippage, when power is applied.

## Air Filters

Energy wheel modules are available with 2-inch filters only. Refer to product catalog CLCH-PRC003-EN for filter sizes, types, and quantities.

### **WARNING** **Hazardous Voltage!**

**Disconnect all electric power, including remote disconnects before servicing. Follow proper lockout/tagout procedures to ensure the power can not be inadvertently energized. Failure to disconnect power before servicing could result in death or serious injury.**

## Throwaway Filters

To replace throwaway filters, install new filters with the directional arrows pointing in the direction of airflow.

## Permanent Filters

To clean permanent filters:

1. Disconnect all electrical power to the unit.
2. Wash the filter under a stream of water to remove dirt and lint.
3. Remove oil from the filter with a wash of mild alkali solution.
4. Rinse the filter in clean, hot water and allow to dry.
5. Coat both sides of the filter by immersing or spraying it with Air Maze Filter Lote W or an equivalent.
6. Allow to drain and dry for about 12 hours.
7. Reinstall the filter.

*Note: It may be preferable to keep extra, clean filters to replace the dirty filters to minimize unit downtime for filter maintenance.*

# Service and Repair

## **⚠ WARNING** Hazardous Voltage!

Disconnect all electric power, including remote disconnects before servicing. Follow proper lockout/tagout procedures to ensure the power can not be inadvertently energized. Failure to disconnect power before servicing could result in death or serious injury.

## **⚠ CAUTION** Sharp edges

Protect hands and belt from sharp edges around hole in bearing support beam. Failure to do so may result in minor or moderate injury.

## Bearing/Drive Belt Replacement

### For sizes 10 to 50

Bearing removal on the pulley side of the wheel is required to remove and replace the drive belt for unit sizes 10 to 50. Bearing removal is discussed first in this procedure.

1. Disconnect all electrical power.
2. Obtain access to the pulley side bearing access plate.
3. Remove the two bearing access plate retaining screws and the access plate.
4. Using a hexagonal wrench, loosen the set screw in the bearing locking collar.
5. Using a light hammer and a drift placed in the drift pin hole in the collar, tap the collar in the opposite direction of wheel rotation to unlock it.
6. Remove the collar.
7. Using a socket wrench with an extension, remove the two nuts

- that secure the bearing housing to the bearing support beam.
8. Slide the bearing from the shaft. Note that slight hand pressure against the wheel rim will lift the weight of wheel from the inner race of the bearing to assist in its removal and installation. The use of a bearing puller may be required.
9. Using a wrench, remove the diameter seal retaining screws or hub seal retaining screws and remove the diameter seals or hub seals from the bearing beam. See Figure 16 for an exploded view of the shaft, bearings, belt, etc.
10. Remove the old belt. Form a small loop of belt and pass it through the hole in the bearing support beam.
11. Grasp the belt at the wheel hub and pull the entire belt down..
- 12.
13. Loop the trailing end of the belt over the shaft. Figure 16 shows the belt partially through the opening.
14. Re-install the bearing onto the wheel shaft, being careful to engage the two locating pins into the holes in the bearing support beam.
15. Secure the bearing with two self-locking nuts.
16. Install the belt around the wheel and pulley according to the instructions provided with the belt.
17. Re-install the diameter seals or hub seal and tighten the retaining screws.

**Figure 16. For belt replacement, loop the trailing end of the belt over the shaft (shown with diameter seals removed)**

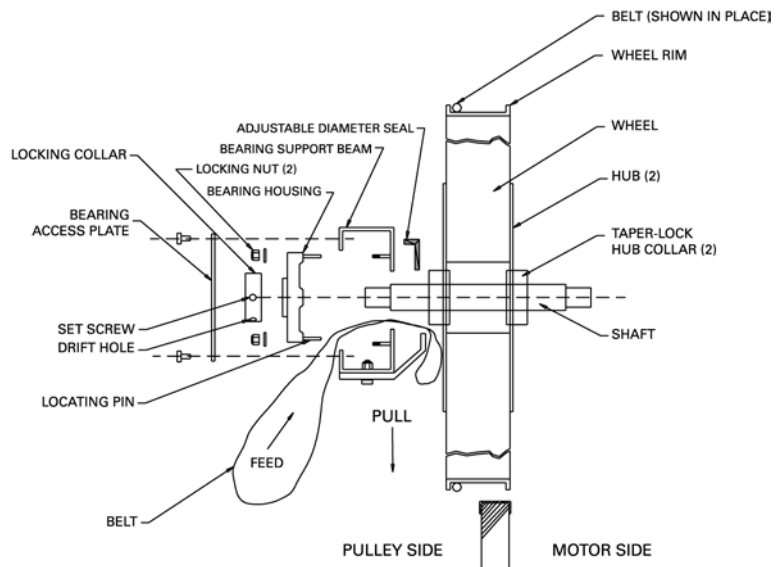

18. Adjust the seals according to the procedure in "Seal Adjustment" on page 17.
19. Rotate the wheel in a clockwise direction to confirm that it rotates freely with slight drag on seals.
20. Re-install the bearing locking collar.
21. Rotate the collar by hand in the direction of wheel rotation.
22. Lock the collar in position by tapping the drift pin hole with a hammer and drift.
23. Secure the collar in position by tightening the set screw.
24. Re-install the bearing access cover.
25. Apply power to the wheel and ensure that the wheel rotates freely without interference.

### For sizes 3 to 8

Bearing removal is not required on slide-out cassettes, unit sizes 3 to 8. These belts may be replaced by temporarily dismounting and rotating the pulley side bearing beam to allow the new belt to be installed on the wheel rim.

1. Disconnect electrical power to the energy wheel.
2. Remove the access panel.
3. Disconnect all controls wiring.
4. Slide the entire cassette assembly out of the module.
5. Loosen the two set screws on the wheel support beam bearings, one on each side of wheel.
6. Remove the belt from the pulley and temporarily position it around the rim.
7. Remove the pulley side wheel support beam with the bearing.

8. Pull the wheel with the shaft straight out of the motor side wheel support beam and bearing (see Figure 17). Do not disassemble the bearings from the beam unless they require replacement. Handle the wheel with care to avoid distorting the wheel.

**Figure 17. Unit sizes 3 to 8 bearing assembly**

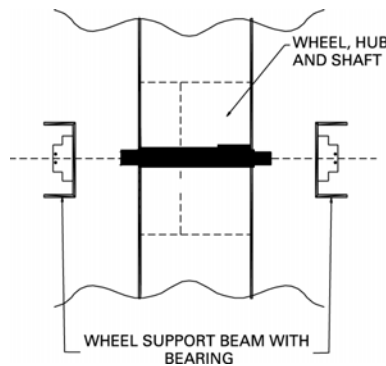

9. Reverse the removal procedure to re-install. Check to ensure that the wheel remains in the center of the seal plate opening.

## Seal Adjustment

1. Loosen the diameter seal adjustment screws and back the seals away from the wheel surface (see Figure 18).
2. Rotate the wheel clockwise until two opposing spokes are hidden behind the bearing support beam.
3. Using a folded piece of paper as a feeler gauge, position the paper between the wheel surface and the diameter seals.
4. Adjust the seals toward the wheel surface until slight friction on the paper feeler gauge is felt when the gauge is moved along the length of the spoke.
5. Check the adjustment through a full rotation of the wheel.
6. Retighten the adjusting screws and recheck the clearance with the paper feeler gauge.

**Figure 18. To adjust seal, loosen screws, back seals away from wheel surface. Seal seen from bottom section.**

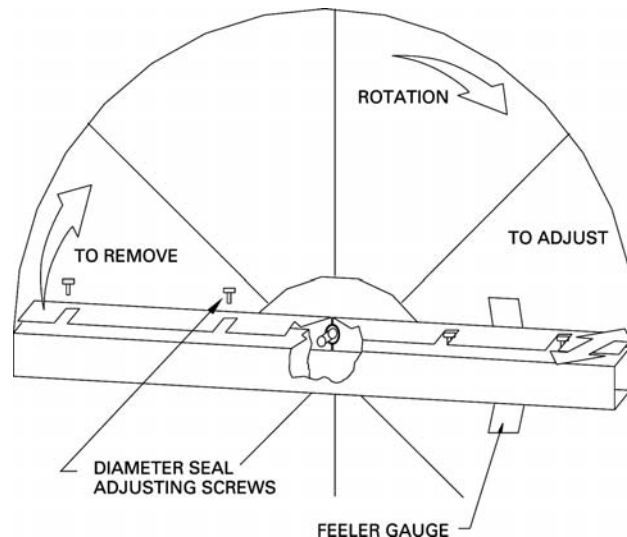

**⚠ WARNING**  
**Hazardous Voltage!**

**Disconnect all electric power, including remote disconnects before servicing. Follow proper lockout/tagout procedures to ensure the power can not be inadvertently energized. Failure to disconnect power before servicing could result in death or serious injury.**

## **Drive Motor and Pulley Replacement**

1. Disconnect all electrical power.
2. Remove the belt from the pulley and temporarily position it around the wheel rim.
3. Measure and record the distance from the inner edge of the pulley to the mounting wall.
4. Loosen the set screw in the wheel drive pulley using an Allen wrench and remove the pulley from the motor drive shaft.
5. While supporting the weight of the drive motor in one hand, loosen and remove the four mounting bolts.
6. Install a replacement motor with the hardware kit supplied.
7. Install the pulley and adjust it to the distance recorded in the previous step.
8. Tighten the set screw to the drive shaft.
9. Stretch the belt over the pulley and engage it in the groove.

# Troubleshooting

## **WARNING** **Hazardous Voltage!**

Disconnect all electric power, including remote disconnects before servicing. Follow proper lockout/tagout procedures to ensure the power can not be inadvertently energized. Failure to disconnect power before servicing could result in death or serious injury.

## **WARNING** **Toxic Hazards!**

Do not use an energy wheel in an application where the exhaust air is contaminated with harmful toxins or biohazards, which could result in death or serious injury.

## **WARNING** **Rotating Parts!**

Disconnect all electrical and remote disconnects before servicing. Secure drive sheaves to ensure rotor cannot freewheel. Keep hands away from the rotating wheel! Contact with the rotating wheel can cause physical injury.

**Table 4. Troubleshooting energy wheels**

Symptom	Probable Cause	Recommended Action	
Wheel will not rotate	Motor is not running	The fuse or circuit breaker may be blown or open. Check the breaker/fuse box and replace.	
		There may be a loss of incoming power. Attempt to trace the power loss back to its source and correct.	
		The motor may have failed. Check for power at the motor terminals. If present, disconnect the belt from the motor pulley and see if the motor runs without a load. If it still doesn't run, replace the motor.	
		The motor may have failed because it is connected to a variable frequency drive. Disconnect the VFD and run the motor on 60 Hz power only.	
	Excessive friction at the seals	Re-adjust the diameter seals per the Seal Adjustment procedure.	
	Energy wheel frame or spokes are bent or warped	Inspect the wheel, locate the bent section, and straighten the section or replace the frame.	
Loss of wheel capacity	During winter operation, excessive frost/ice forms in the heat transfer media	Disconnect power to the wheel motor, adjust outside air dampers shut and let the wheel thaw. After the initial section thaws, rotate the wheel 90° by hand until the "new" section rotates into the warm exhaust air stream. Continue this procedure until the wheel is completely thawed.	
	Drive belt is broken	Inspect visually. Replace the drive belt.	
	Wheel main shaft bearing is seized	Replace the seized bearing.	
	Wheel is not rotating	See above	
		Wheel is rotating too slowly	Belt is stretched, slipping. Replace the belt
			Ice forms on the wheel; thaw per above.
			Seized bearing on the main shaft; replace the bearing.
	Energy transfer surface is contaminated	Excessive friction in seals; adjust.	
		Clean the energy transfer surfaces. Consider purchasing a second set of energy transfer segments for continuous operation while cleaning.	
		Replace the energy transfer segments if they are severely contaminated and cannot be cleaned. Consider adding a contaminate filter before (upstream) the energy wheel.	
Frost/ice forms on heat transfer surfaces	Thaw the wheel surfaces per procedure above. Consider adding outside air preheat.		
Worn diameter seals	Maximum wheel pressure drop exceeded	Adjust wheel airflow so that the pressure drop across the wheel is less than 1.25 inches wg.	
	Seal adjusted too tight	Adjust seals per procedure in "Seal Adjustment" on page 17.	



**Trane**  
**A business of American Standard Companies**  
**[www.trane.com](http://www.trane.com)**

*For more information, contact your local Trane office or e-mail us at [comfort@trane.com](mailto:comfort@trane.com)*

---

Literature Order Number	CLCH-SVX02C-EN
File Number	SV-AH-CLCH-MCCB-SVX02C-EN-0204
Supersedes	CLCH-SVX02B-EN (August 2001)
Stocking Location	Inland

---

Trane has a policy of continuous product and product data improvement and reserves the right to change design and specifications without notice.