



Installation/ Operator Maintenance

VarTrane™ Single-Duct and Fan-Powered Units



All VarTrane VAV Models with pneumatic, electronic, DDC controls and diffusers.



Contents

Service Model Number Description	4 – 14
General Information	15
Literature Contents	
Receiving and Handling	
Warnings and Cautions Explanations	
Unit Information	16 – 17
Single-Duct Units	
Dual-Duct Units	
Fan-Powered and Low-Height Units	
Unit Installation	18 – 31
Hanging Bracket Locations	
Unit Weights	
Water Coil Connections	
Unit Accessibility	
Clearances	
Actuator Mounting	
Unit Setup	32 – 46
Flow Sensor ΔP vs. Airflow Delivery	
Maximum Fan Motor Amperage	
(SCR) Motor Speed Control Adjustment Procedure	
Electrically Commutated Motor (ECM)	
ECM CFM Tables	
Wiring Diagrams	47 – 54
Maintenance	55
Motors	
Fan Wheel	
Filter	
Water Coil	
Fan Motor Replacement	
Installation of Diffusers	56
T-Bar Ceiling	
Concealed Spline Ceiling	
Drywall/Plaster Ceiling	



Service Model Number Description

▲ WARNING

Fiberglass Wool!

WARNING: ALL INSULATED UNITS (except closed-cell foam insulation) CONTAIN FIBERGLASS WOOL! Read this literature prior to installation for proper instruction. Disturbing the insulation in this product during installation, maintenance or repair will expose you to airborne particles of glass wool fibers and ceramic fibers known to the state of California to cause cancer through inhalation. Glass wool fibers may also cause respiratory, skin or eye irritation.

Single-Duct Units

Digit 1, 2—Unit Type

VC VariTrane single-duct

Digit 3—Reheat

C Cooling Only
E Electric Heat
W Hot Water Heat

Digit 4—Development Sequence

F Sixth

Digit 5, 6—Primary Air Valve

04 4" inlet (225 cfm)
05 5" inlet (350 cfm)
06 6" inlet (500 cfm)
08 8" inlet (900 cfm)
10 10" inlet (1400 cfm)
12 12" inlet (2000 cfm)
14 14" inlet (3000 cfm)
16 16" inlet (4000 cfm)
24 24" x 16" inlet (8000 cfm)

Digit 7, 8—Not Used

00 N/A

Digit 9—Not Used

0 N/A

Digit 10, 11—Design Sequence

H0 Fourth (factory assigned)

Digit 12, 13, 14, 15—Controls

ENON No controls, field-installed DDC/electric
PNON No controls, field-installed pneumatic
DD00 Trane elec actuator only
DD01 DDC – Cooling only
DD02 DDC – N.C. on/off water valve control
DD03 DDC – Prop hot water valve control
DD04 DDC – On/off electric heat
DD05 DDC – Pulse-width modulation electric heat
DD07 DDC – N.O. on/off water valve control
DD11 LonTalk DDC Controller—Cooling only
DD12 LonTalk DDC Controller w/ N.C. on/off hot water control
DD13 LonTalk DDC Controller w/ proportional hot water control
DD14 LonTalk DDC Controller—on/off electric heat control
DD15 LonTalk DDC Controller w/ pulse-width modulation electric heat control
DD17 LonTalk DDC Controller w/ N.O. on/off hot water control

FM00 FM – Customer-supplied actuator & controller
FM01 FM – Trane actuator w/ customer-supplied control
VMA1 FM – Johnson controls VMA-1410
VMA2 FM – Johnson controls VMA-1420
PWR1 FM – Seimens 540-100 w/ GDE131.1P actuator
PWR4 FM – Seimens 540-100 w/Trane actuator
PWR5 FM – Seimens 540-100 w/ GDE131.1U actuator
AT01 FM – Automated Logic U341V+
AT02 FM – Automated Logic U141V+
EI05 Analog – With optional on/off reheat
EI28 Analog – With optional on/off reheat with dual-minimum cfm
EI29 Analog – With optional on/off reheat with constant-volume cfm
PC00 PN – N.C. Trane pneumatic actuator
PC04 PN – N.C. with optional on/off HW, DA Stat
PC05 PN – N.C. with optional on/off electric, RA Stat
PN00 PN – N.O. Trane pneumatic actuator, RA Stat
PN04 PN – N.O. PVR, DA Stat
PN05 PN – N.O. PVR, RA Stat
PN11 PN – N.O. dual-minimum cfm, DA Stat
PN32 PN – Water Valve, N.O. constant volume, DA Stat
PN34 PN – Electric heat, N.O. constant volume, DA Stat

Notes:

N.C. = Normally-closed

N.O. = Normally-opened

DA Stat = Direct-acting pneumatic t-stat (by others)

RA Stat = Reverse-acting pneumatic t-stat (by others)

PN = Pneumatic

FM = Factory installation of customer-supplied controller

PVR = Pneumatic Volume Regulator

Digit 16—Insulation

A 1/2" Matte-faced
B 1" Matte-faced
C 1/2" Foil-faced
D 1" Foil-faced
F 1" Double-wall
G 3/8" Closed-cell



Service Model Number Description

Single-Duct Units (con't.)

Digit 17— Not Used

0 N/A

Digit 18— Not Used

0 N/A

Digit 19— Outlet Plenum (Connection is Slip & Drive)

0 None
 A 1 Outlet RH
 B 1 Outlet END
 C 1 Outlet LH
 D 2 Outlets, 1 RH, 1 END
 E 2 Outlets, 1 LH, 1 END
 F 2 Outlets, 1 RH, 1 LH
 H 3 Outlets, 1 LH, 1 RH, 1 END
 J 4 Outlets, 1 LH, 1 RH, 2 END

Note: See unit drawings for outlet sizes/damper information.

Digit 20— Not Used

0 N/A

Digit 21— Water Coil

0 None
 1 1-Row
 2 2-Row

Digit 22— Electrical Connections (VCCF, VCWF can be flipped in the field to achieve opposite-hand connection)

L Left (Airflow hitting you in the face)
 R Right (Airflow hitting you in the face)
 0 Opposite side connection – coil and control

Digit 23— Transformer

0 None
 1 120/24 volt (50 VA)
 2 208/24 volt (50 VA)
 3 240/24 volt (50 VA)
 4 277/24 volt (50 VA)
 5 480/24 volt (50 VA)
 6 347/24 Volt (50 VA)
 7 575/24 Volt (50 VA)
 8 380/24 Volt (50 VA)

Note: For VCEF units with transformers the VA depends on the staging, control, and contactor type (ranges are 40 VA to 75 VA)

Digit 24— Disconnect Switch

0 None
 W With

Note: VCCF, VCWF – Toggle Disconnect
 VCEF – Door Interlocking Power Disconnect

Digit 25— Power Fuse

0 None
 W With

Digit 26— Electric Heat Voltage

0 None
 A 208/60/1
 B 208/60/3
 C 240/60/1
 D 277/60/1
 E 480/60/1
 F 480/60/3
 G 347/60/1
 H 575/60/3
 J 380/50/3
 K 120/60/1

Digit 27, 28, 29— Electric Heat kW

000	None
050	0.5 kW
010	1.0 kW
015	1.5 kW
↓	↓
460	46.0 kW

Notes:

0.5 to 8.0 kW – ½ kW increments
 8.0 to 18.0 kW – 1 kW increments
 18.0 to 46.0 kW – 2 kW increments

Digit 30— Electric Heat Stages

0 None
 1 1 Stage
 2 2 Stages Equal
 3 3 Stages Equal

Digit 31— Contactors

0 None
 1 24-volt magnetic
 2 24-volt mercury
 3 PE with magnetic
 4 PE with mercury

Digit 32— Not Used

0 N/A



Service Model Number Description

Dual-Duct Units

Digit 1, 2, 3—Unit Type

VDD VariTrane dual-duct

Digit 4—Development Sequence

F Sixth

Digit 5, 6—Primary Air Valve

05 5" inlet (350 cfm)
 06 6" inlet (500 cfm)
 08 6" inlet (900 cfm)
 10 10" inlet (1400 cfm)
 12 12" inlet (2000 cfm)
 14 14" inlet (3000 cfm)
 16 16" inlet (4000 cfm)

Digit 7, 8—Secondary Air Valve

05 5" inlet (350 cfm)
 06 6" inlet (500 cfm)
 08 8" inlet (900 cfm)
 10 10" inlet (1400 cfm)
 12 12" inlet (2000 cfm)
 14 14" inlet (3000 cfm)
 16 16" inlet (4000 cfm)

Digit 9—Not Used

0 N/A

Digit 10, 11—Design Sequence

C0 Third (factory assigned)

Digit 12, 13, 14, 15—Controls

ENON No Controls, Field-installed
 DDC/Electric
 PNON No Controls, Field-installed
 Pneumatic
 DD00 Trane elec actuator only
 DD01 DDC – Cooling only
 DD08 DDC – Constant-volume
 discharge
 DD11 LonTalk DDC Controller—
 Cooling only
 DD18 LonTalk DDC Controller—
 Constant Volume Discharge

FM00 FM – Customer-supplied
 actuator & controller
 FM01 FM – Trane actuator w/
 customer-supplied controller
 PC03 PN – N.C. heating/ N.O. cooling
 w/ PVRs, DA stat
 PN08 PN – N.O. heating/ N.O. cool
 act. only, RA stat
 PN09 PN – N.O. htg/clg vlvs w/ PVRs,
 DA stat
 PN10 PN – N.O. htg/clg w/ PVRs (cv
 disch), DA stat.

Notes:

N.C. = Normally-closed

N.O. = Normally-opened

DA Stat = Direct-acting pneumatic t-stat
 (by others)

RA Stat = Reverse-acting pneumatic t-stat
 (by others)

PN = Pneumatic

FM = Factory installation of customer-
 supplied controller

PVR = Pneumatic Volume Regulator

Digit 16—Insulation

A 1/2" Matte-faced
 B 1" Matte-faced
 C 1/2" Foil-faced
 D 1" Foil-faced
 F 1" Double-wall
 G 3/8" Closed-cell

Digit 17—Not Used

0 N/A

Digit 18—Not Used

0 N/A

Digit 19—Outlet Plenum (Connection is slip & drive)

0 none
 A 1 outlet–RH
 B 1 outlet–END
 C 1 outlet–LH
 D 2 outlets–1 RH, 1 END
 E 2 outlets–1 LH, 1 END
 F 2 outlets–1 RH, 1 LH
 G 2 outlets – END
 H 3 outlets–1 LH, 1 RH, 1 END
 J 4 outlets–1 LH, 1 RH, 2 END

**Note: See unit drawings for outlet sizes/
 damper information.**

Digit 20—Not Used

0 N/A

Digit 21—Not Used

0 N/A

Digit 22—Not Used

0 N/A

Digit 23—Transformer

0 None
 1 120/24 volt (50 VA)
 2 208/24 volt (50 VA)
 3 240/24 volt (50 VA)
 4 277/24 volt (50VA)
 5 480/24 volt (50 VA)
 6 347/24 volt (50 VA)
 7 575/24 volt (50 VA)

Digit 24—Disconnect Switch

0 None
 W With Toggle

Digit 25—Power Fuse

0 None
 W With

Service Model Number Description

Fan-Powered Parallel Units

Digit 1, 2—Unit Type

VP VariTrane fan-powered parallel

Digit 3—Reheat

C Cooling Only
E Electric Heat
W Hot Water Heat

Digit 4—Development Sequence

F Sixth

Digit 5, 6—Primary Air Valve

05 5" inlet (350 max cfm)
06 6" inlet (500 max cfm)
08 8" inlet (900 max cfm)
10 10" inlet (1400 max cfm)
12 12" inlet (2000 max cfm)
14 14" inlet (3000 max cfm)
16 16" inlet (4000 max cfm)

Digit 7, 8—Secondary Air Valve

00 N/A

Digit 9—Fan

P 02SQ fan (500 nominal cfm)
Q 03SQ fan (1100 nominal cfm)
R 04SQ fan (1350 nominal cfm)
S 05SQ fan (1550 nominal cfm)
T 06SQ fan (1850 nominal cfm)
U 07SQ fan (2000 nominal cfm)

Digit 10, 11—Design Sequence

J0 Design Sequence (Factory assigned)

Digit 12, 13, 14, 15—Controls

ENON No controls, field-installed DDC or analog

ENCL ENON with controls enclosure

PNON No controls, field-installed

pneumatic

DD00 Trane elec actuator only

DD01 DDC – cooling only

DD02 DDC – N.C. on/off water control

DD03 DDC – prop hot water control

DD04 DDC – on/off electric heat

control

DD05 DDC – pulse-width modulation

electric heat control

DD07 DDC – N.O. on/off hot water

control

DD11 LonTalk DDC Controller—

Cooling only

DD12 LonTalk DDC Controller w/ N.C.

on/off hot water control

DD13 LonTalk DDC Controller w/

proportional hot water control

DD14 LonTalk DDC Control-on/off

electric heat control

DD15 LonTalk DDC Controller w/ pulse-width modulation electric heat control

DD17 LonTalk DDC Controller w/ N.O. on/off hot water control

FM00 FM customer actuator & control

FM01 FMTrane actuator w/ customer-

supplied controller

VMA2 FM Johnson Controls

VMA-1420

PWR1 FM Seimens 540-100 w/

GDE131.1P actuator

PWR4 FM Seimens 540-100 w/Trane

actuator

PWR5 FM Seimens 540-100 w/

GDE131.1U actuator

AT01 FM Automated Logic U341V+

AT02 FM Automated Logic U141V+

EI05 Analog – fan-powered parallel

with optional on/off reheat

PN00 PN – N.O. Trane pneumatic

actuator, R.A. stat

PN05 PN – N.O. PVR, R.A. stat

Notes:

N.C. = Normally-closed

N.O. = Normally-opened

DA Stat = Direct-acting pneumatic t-stat (by others)

RA Stat = Reverse-acting pneumatic t-stat (by others)

PN = Pneumatic

FM = Factory installation of customer-supplied controller

PVR = Pneumatic Volume Regulator

Digit 16—Insulation

A 1/2" Matte-faced

B 1" Matte-faced

C 1/2" Foil-faced

D 1" Foil-faced

F 1" Double-wall

G 3/8" Closed-cell

Digit 17—Motor Type

D PSC Motor

E High-efficiency motor (ECM)

Digit 18—Motor Voltage

1 115/60/1

2 277/60/1

3 347/60/1

4 208/60/1

5 230/50/1

Digit 19—Outlet Connection

1 Flanged

2 Slip & Drive

Digit 20—Attenuator

0 None

W With

Digit 21—Water Coil

0 None

1 1-Row-Plenum inlet installed RH

2 2-Row-Plenum inlet installed RH

3 1-Row-Discharge installed, LH

4 1-Row-Discharge installed, RH

5 2-Row-Discharge installed, LH

6 2-Row-Discharge installed, RH

Digit 22—Electrical Connections

L Left

R Right

Electrical Connections Note: Airflow hitting you in the face.

Digit 23—Transformer

0 N/A (provided as standard)

Digit 24—Disconnect Switch

0 None

W With

**Note: VPCF/VPWF – Toggle Disconnect
VPEF – Door Interlocking Power
Disconnect**

Digit 25—Power Fuse

0 None

W With

Digit 26—Electric Heat Voltage

0 None

A 208/60/1

B 208/60/3

C 240/60/1

D 277/60/1

E 480/60/1

F 480/60/3

G 347/60/1

H 575/60/3

J 380/50/3

K 120/60/1

Digit 27, 28, 29—Electric Heat Voltage

000 None

050 0.5 kW

010 1.0 kW

015 1.5 kW

↓ ↓

260 26.0 kW

**Electric Heat Voltage Notes:
0.5 to 8.0 kW—½ kW increments
8.0 to 18.0 kW—1 kW increments
18.0 to 46.0 kW—2 kW increments**



Service Model Number Description

Fan-Powered Parallel Units (con't)

Digit 30—Electric Heat Stages

- 0 None
- 1 1 Stage
- 2 2 Stages Equal
- 3 3 Stages Equal

Digit 31—Contactors

- 0 None
- 1 24-volt magnetic
- 2 24-volt mercury
- 3 PE with magnetic
- 4 PE with mercury

Digit 32—Airflow Switch

- 0 None
- W With

Service Model Number Description

Fan-Powered Series Units

Digit 1, 2—Unit Type

VS VariTrane fan-powered series

Digit 3—Reheat

C Cooling Only
E Electric Heat
W Hot Water Heat

Digit 4—Development Sequence

F Sixth

Digit 5, 6—Primary Air Valve

04 4" inlet (225 max cfm)
05 5" inlet (350 max cfm)
06 6" inlet (500 max cfm)
08 8" inlet (900 max cfm)
10 10" inlet (1400 max cfm)
12 12" inlet (2000 max cfm)
14 14" inlet (3000 max cfm)
16 16" inlet (4000 max cfm)

Digit 7, 8—Secondary Air Valve

00 N/A

Digit 9—Fan

P 02SQ fan (700 nominal cfm)
Q 03SQ fan (1200 nominal cfm)
R 04SQ fan (1550 nominal cfm)
S 05SQ fan (1900 nominal cfm)
T 06SQ fan (2600 nominal cfm)
U 07SQ fan (3000 nominal cfm)

Fan Note: See fan curves for specific airflows

Digit 10, 11—Design Sequence

J0 Design Sequence
(Factory assigned)

Digit 12, 13, 14, 15—Controls

ENON No controls, field-installed DDC or analog
ENCL ENON with control enclosure
PNON No controls, field-installed pneumatic
DD00 Trane elec actuator only
DD01 DDC – cooling only
DD02 DDC – N.C. on/off water control
DD03 DDC – prop hot water control
DD04 DDC – on/off electric heat control
DD05 DDC – pulse-width modulation electric heat control
DD07 DDC N.O. on/off hot water control
DD11 LonTalk DDC Controller—Cooling only
DD12 LonTalk DDC Controller w/ N.C. on/off hot water control

DD13 LonTalk DDC Controller w/ proportional hot water control
DD14 LonTalk DDC Controller—on/off electric heat control
DD15 LonTalk DDC Controller w/ pulse-width modulation electric heat control
DD17 LonTalk DDC Controller w/ N.O. on/off hot water control
FM00 FM customer actuator & control
FM01 FMTrane actuator w/ customer-supplied controller
VMA2 FM Johnson controls VMA-1420
PWR1 FM Seimens 540-100 w/ GDE131.1P actuator
PWR4 FM Seimens 540-100 w/Trane actuator
PWR5 FM Seimens 540-100 w/ GDE131.1U actuator
AT01 FM Automated Logic U341V+
AT02 FM Automated Logic U141V+
EI71 Analog fan-powered series with optional on/off reheat
PN00 PN – N.O. Trane pneumatic actuator, R.A. stat
PN51 PN – N.O. PVR, duct pressure switch, R.A. stat
PN52 PN – N.O. PVR, dual pressure main, R.A. stat

Notes:

N.C. = Normally-closed

N.O. = Normally-opened

DA Stat = Direct-acting pneumatic t-stat (by others)

RA Stat = Reverse-acting pneumatic t-stat (by others)

PN = Pneumatic

FM = Factory installation of customer-supplied controller

PVR = Pneumatic Volume Regulator

Digit 16—Insulation

A 1/2" Matte-faced
B 1" Matte-faced
C 1/2" Foil-faced
D 1" Foil-faced
F 1" Double-wall
G 3/8" Closed-cell

Digit 17—Motor Type

D PSC Motor
E High-efficiency motor (ECM)

Digit 18—Motor Voltage

1 115/60/1
2 277/60/1
3 347/60/1
4 208/60/1
5 230/50/1

Digit 19—Outlet Connection

1 Flanged
2 Slip & Drive

Digit 20—Attenuator

0 None
W With

Digit 21—Water Coil

0 None
3 1-Row-Discharge installed, LH
4 1-Row-Discharge installed, RH
5 2-Row-Discharge installed, LH
6 2-Row-Discharge installed, RH

Digit 22—Electrical Connections

L Left
R Right

Water Coil and Electrical Connections
Note: Airflow hitting you in the face.

Digit 23—Transformer

0 N/A (provided as standard)

Digit 24—Disconnect Switch

0 None
W With

Note: **VSCF/VSWF – Toggle Disconnect**
VSEF – Door Interlocking Power Disconnect

Digit 25—Power Fuse

0 None
W With

Digit 26—Electric Heat Voltage

0 None
A 208/60/1
B 208/60/3
C 240/60/1
D 277/60/1
E 480/60/1
F 480/60/3
G 347/60/1
H 575/60/3
J 380/50/3
K 120/60/1



Service Model Number Description

Fan-Powered Series Units (con't)

Digit 27, 28, 29—Electric Heat Kilowatts

000	None
050	0.5 kW
010	1.0 kW
015	1.5 kW



240	24.0 kW
-----	---------

Digit 30—Electric Heat Stages

0	None
1	1 Stage
2	2 Stages Equal
3	3 Stages Equal

Digit 31—Contactors

0	None
1	24-volt magnetic
2	24-volt mercury
3	PE with magnetic
4	PE with mercury

Digit 32—Airflow Switch

0	None
W	With



Service Model Number Description

Fan-Powered Low-Height Parallel Units

Digit 1, 2—Unit Type

LP VariTrane fan-powered low-height parallel

Digit 3—Reheat

C Cooling Only
E Electric Heat
W Hot Water Heat

Digit 4—Development Sequence

F Sixth

Digit 5, 6—Primary Air Valve

05 5" inlet (350 maximum cfm)
06 6" inlet (500 maximum cfm)
08 8" inlet (900 maximum cfm)
RT 8" x 14" inlet (1800 maximum cfm)

Digit 7, 8—Secondary Air Valve

00 N/A

Digit 9—Fan

V 08SQ 500 nominal cfm
W 09SQ 900 nominal cfm
X 10SQ 1800 nominal cfm

Digit 10, 11—Design Sequence

K0 Sixth (factory assigned)

Digit 12, 13, 14, 15—Controls

ENON No controls, field-installed DDC/ electric
PNON No controls, field-installed pneumatic
DD00 Trane elec actuator only
DD01 DDC – cooling only
DD02 DDC – N.C. on/off water valve control
DD03 DDC – prop hot water valve control
DD04 DDC – on/off electric heat control
DD05 DDC – pulse-width modulation control
DD07 DDC – N.O. on/off water valve control
DD11 LonTalk DDC Controller—Cooling only
DD12 LonTalk DDC Controller w/ N.C. on/off hot water control
DD13 LonTalk DDC Controller w/ proportional hot water control

DD14 LonTalk DDC Controller—on/off electric heat control
DD15 LonTalk DDC Controller w/ pulse-width modulation electric heat control
DD17 LonTalk DDC Controller w/ N.O. on/off hot water control
FM00 FM customer actuator & control
FM01 FM Trane actuator w/ customer-supplied controller
VMA2 FM Johnson Controls VMA-1420
PWR1 FM Seimens 540-100 w/ GDE131.1P actuator
PWR4 FM Seimens 540-100 w/ Trane actuator
PWR5 FM Seimens 540-100 w/ GDE131.1U actuator
AT01 FM Automated Logic U341V+
AT02 FM Automated Logic U141V+
EI05 Analog – fan-powered parallel with optional on/off reheat
PN00 PN – N.O. Trane pneumatic actuator, R.A. stat
PN05 PN – N.O. PVR, R.A. stat

Notes:

N.C. = Normally-closed
N.O. = Normally-opened
DA Stat = Direct-acting pneumatic t-stat (by others)
RA Stat = Reverse-acting pneumatic t-stat (by others)
PN = Pneumatic
FM = Factory installation of customer-supplied controller
PVR = Pneumatic Volume Regulator

Digit 16—Insulation

A 1/2" Matte-faced
B 1" Matte-faced
C 1/2" Foil-faced
D 1" Foil-faced
F 1" Double-wall
G 3/8" Closed-cell

Digit 17—Motor Type

D PSC Motor
E High-efficiency motor (ECM)

Digit 18—Motor Voltage

1 115/60/1
2 277/60/1
3 347/60/1
5 230/50/1

Digit 19—Outlet Connection

1 Flanged
2 Slip & Drive

Digit 20—Not Used

0 N/A

Digit 21—Water Coil

0 None
1 1-Row-Plenum inlet installed
2 2-Row-Plenum inlet installed
3 1-Row-Discharge installed, LH
4 1-Row-Discharge installed, RH
5 2-Row-Discharge installed, LH
6 2-Row-Discharge installed, RH

Digit 22—Electrical Connections

L Left (airflow hitting you in the face)

Digit 23—Transformer

0 N/A (provided as standard)

Digit 24—Disconnect Switch

0 None
W With

Note: **LPCF, LPWF – Toggle Disconnect**
LPEF – Door Interlocking Power Disconnect

Digit 25—Power Fuse

0 None
W With

Digit 26—Electric Heat Voltage

0 None
A 208/60/1
B 208/60/3
C 240/60/1
D 277/60/1
E 480/60/1
F 480/60/3
G 347/60/1
H 575/60/3
J 380/50/3



Service Model Number Description

Fan-Powered Low-Height Parallel Units (con't)

Digit 27, 28, 29— Electric Heat Voltage

000	None
005	0.5 kW
010	1.0 kW
015	1.5 kW
020	2.0 kW
025	2.5 kW
030	3.0 kW
035	3.5 kW
040	4.0 kW
045	4.5 kW
050	5.0 kW
055	5.5 kW
060	6.0 kW
065	6.5 kW
070	7.0 kW
075	7.5 kW
080	8.0 kW
090	9.0 kW
100	10.0 kW
110	11.0 kW
120	12.0 kW
130	13.0 kW
140	14.0 kW

Digit 30— Electric Heat Stages

0	None
1	1 Stage
2	2 Stages Equal

Digit 31— Contactors

0	None
1	24-volt magnetic
2	24-volt mercury
3	PE with magnetic
4	PE with mercury

Digit 32— Airflow Switch

0	None
W	With



Service Model Number Description

Fan-Powered Low-Height Series Units

Digit 1, 2—Unit Type

LS VariTrane low-height series fan-powered

Digit 3—Reheat

C Cooling Only
E Electric Heat
W Hot Water Heat

Digit 4—Development Sequence

F Sixth

Digit 5, 6—Primary Air Valve

05 5" inlet (350 cfm)
06 6" inlet (500 cfm)
08 8" inlet (900 cfm)
RT (8" x 14" inlet (1800 cfm)

Digit 7, 8—Secondary Air Valve

00 N/A

Digit 9—Fan

V 08SQ 500 nominal cfm
W 09SQ 900 nominal cfm
X 10SQ 1800 nominal cfm

Digit 10, 11—Design Sequence

K0 Sixth (factory assigned)

Digit 12, 13, 14, 15—Controls

ENON No controls, field-installed DDC/electric

PNON No controls, field-installed pneumatic

DD00 Trane elec actuator only

DD01 DDC – cooling only

DD02 DDC – N.C. on/off water valve control

DD03 DDC – prop hot water valve control

DD04 DDC – on/off electric heat control

DD05 DDC – pulse-width modulation control

DD07 DDC – N.O. on/off water valve control

DD11 LonTalk DDC Controller—Cooling only

DD12 LonTalk DDC Controller w/ N.C. on/off hot water control

DD13 LonTalk DDC Controller w/ proportional hot water control

DD14 LonTalk DDC Controller—on/off electric heat control

DD15 LonTalk DDC Controller w/ pulse-width modulation electric heat control

DD17 LonTalk DDC Controller w/ N.O. on/off hot water control

FM00 FM customer actuator & control

FM01 FMTrane actuator w/ customer-supplied controller

VMA2 FM Johnson controls VMA-1420

PWR1 FM Seimens 540-100 w/ GDE131.1P actuator

PWR4 FM Seimens 540-100Trane actuator

PWR5 FM Seimens 540-100 w/ GDE131.1U actuator

AT01 FM Automated Logic U341V+

AT02 FM Automated Logic U141V+

EI71 Analog – Series fan-powered on/off reheat

PN00 PN – N.O. Trane pneumatic actuator, R.A. stat

PN51 PN – N.O. PVR, duct pressure switch, R.A. stat

PN52 PN – N.O. PVR, dual pressure main, R.A. stat

Notes:

N.C. = Normally-closed

N.O. = Normally-opened

DA Stat = Direct-acting pneumatic t-stat (by others)

RA Stat = Reverse-acting pneumatic t-stat (by others)

PN = Pneumatic

FM = Factory installation of customer-supplied controller

PVR = Pneumatic Volume Regulator

Digit 16—Insulation

A 1/2" Matte-faced

B 1" Matte-faced

C 1/2" Foil-faced

D 1" Foil-faced

F 1" Double-wall

G 3/8" Closed-cell

Digit 17—Motor Type

D PSC Motor

E High-efficiency motor (ECM)

Digit 18—Motor Voltage

1 115/60/1

2 277/60/1

3 347/60/1

5 230/50/1

Digit 19—Outlet Connection

1 Flanged

2 Slip & Drive

Digit 20—Not Used

0 N/A

Digit 21—Water Coil

0 None

3 1-Row-Discharge installed, LH

4 1-Row-Discharge installed, RH

5 2-Row-Discharge installed, LH

6 2-Row-Discharge installed, RH

Digit 22—Electrical Connections

L Left (airflow hitting you in the face)

R Right (airflow hitting you in the face)

Digit 23—Transformer

0 N/A (provided as standard)

Digit 24—Disconnect Switch

0 None

W With

Note: **LSCF, LSWF – Toggle Disconnect**
LSEF – Door Interlocking Power Disconnect

Digit 25—Power Fuse

0 None

W With

Digit 26—Electric Heat Voltage

0 None

A 208/60/1

B 208/60/3

C 240/60/1

D 277/60/1

E 480/60/1

F 480/60/3

G 347/60/1

H 575/60/3

J 380/50/3



Service Model Number Description

Fan-Powered Low-Height Series Units (con't)

Digit 27, 28, 29— Electric Heat Voltage

000	None
005	0.5 kW
010	1.0 kW
015	1.5 kW
020	2.0 kW
025	2.5 kW
030	3.0 kW
035	3.5 kW
040	4.0 kW
045	4.5 kW
050	5.0 kW
055	5.5 kW
060	6.0 kW
065	6.5 kW
070	7.0 kW
075	7.5 kW
080	8.0 kW
090	9.0 kW
100	10.0 kW
110	11.0 kW
120	12.0 kW
130	13.0 kW
140	14.0 kW
150	15.0 kW
160	16.0 kW
170	17.0 kW
180	18.0 kW

Digit 30— Electric Heat Stages

0	None
1	1 Stage
2	2 Stages Equal

Digit 31— Contactors

0	None
1	24-Volt magnetic
2	24-Volt mercury
3	PE with magnetic
4	PE with mercury

Digit 32— Air Flow Switch

0	None
W	With

General Information

Literature Contents

This manual describes the installation of VariTrane VAV units with recommended wiring, piping, and mounting of Single-Duct, Dual-Duct, Fan-Powered, Low-Height terminal units and diffusers.

Receiving and Handling

VariTrane Units are shipped completely assembled with the exceptions of optional attenuators for fan-powered units and accessories.

Upon receiving the equipment, complete the following:

- Locate the nameplate and refer to the model and sales order number and check that the correct units have been delivered.
- Inspect the control enclosures and air valve casing for dents or punctures.

- Verify that all options have been included, such as filters, controls, heating coils, water valves, etc. Also check that the unit voltages agree with the building parameters.
- Manually rotate the fan (if applicable) to assure that there are no obstructions within the housing.
- Claims for in-transit damage must be filed immediately with the delivery carrier.
- For hot water re-heat units, check the coil fins and make sure that coils are not damaged.
- Locate and verify that the correct zone sensors are with the order. These will be marked with an orange "Accessories Enclosed" label. Store in a secure location until needed. Accessories lost at the jobsite are NOT covered by Trane's warranty.

- If a discrepancy occurs between what was ordered and what is received, contact your local Trane representative immediately.
- Read the appropriate section in this manual for installation procedures prior to actual starting of equipment.

Upon receiving the equipment, please inspect each unit and components for external or internal damage. Refer to the bill of lading to insure all equipment and accessories have been received. Contact your local Trane sales representative and notify the trucking company immediately of any short ship or damaged equipment.

NOTICE:

Warnings and Cautions appear at appropriate sections throughout this manual. Read these carefully.

▲ WARNING – Indicates a potentially hazardous situation which, if not avoided, could result in death or serious injury.

▲ CAUTION – Indicates a potentially hazardous situation which, if not avoided, may result in minor or moderate injury. It may also be used to alert against unsafe practices.

CAUTION – Indicates a situation that may result in equipment or property-damage-only accidents.

Unit Information

Single-Duct Units

The basic unit consists of a sheet metal casing with an air valve, which is used to modulate the air being delivered into the occupied zone. The unit is designed to modulate either cooling or heating air between the temperatures of 40°F and 140°F. Air enters the air valve through the round or rectangular inlet and exits into the sheet metal casing to be distributed to the zone either through integral round outlets in the casing or through rectangular duct attached to the discharge of the unit.

The basic unit can also be ordered with factory-mounted electric or hot water heating coils attached to the discharge. (See Figure 1.)

These re-heat units are used primarily to reheat air-to-zone temperature when the load in the occupied space is low.

Primary air is modulated through the VariTrane air valve by rotating the damper blade. All air valves have a round/rectangular inlet for easy fit-up with incoming ductwork.

Figure 1 – Typical Single-Duct Units



VCCF



VCWF



VCEF

Dual-Duct Units

Dual-duct units provide two air valves: one as heating primary air and the other as cooling primary air. Both discharge into the common outlet, which leads to the zone being controlled. (See Figure 2.)

The units are provided with a slip and drive rectangular duct connection or can be ordered with integral outlet plenum.

Sequencing of the hot and cold air valve is dependent upon job requirements. One typical control is the valves working in conjunction with each other to respond to zone temperature.

When the cooling valve becomes fully closed or reaches a specified minimum, then the heating valve will begin to modulate or vice versa. The typical result is that air flowing to the zone varies from the maximum down to a minimum and back up to a maximum as the load varies and as the controls would cause one air valve to close and the other to open.

Another typical application is when the unit provides a constant volume to the zone. When the zone sensor is tied directly to the heating valve, it will modulate the heating valve according to the zone temperature.

When the heating valve is fully closed or there is a call for cooling in the zone, the cooling valve will be at constant supply. As the space becomes too cool, the heating valve will modulate open, decreasing the cooling valve flow. The typical result is that the air flowing into the zone stays at a constant flow whether the unit is heating or cooling.

Figure 2 – Typical Dual-Duct Unit



VDDF

Unit Information

Fan-Powered and Fan-Powered Low-Height Units

VariTrane fan-powered and low-height fan-powered units can be either parallel or series, with or without re-heat. (See Figure 3.)

The fan on a series unit runs continuously whenever the main air handler unit is in operation. There are various options for starting the fan. The fan can be started three ways: 1) remotely, 2) by a duct pressure switch, or 3) by a combination of both. The particular fan control method may vary from unit to unit, depending upon job needs.

Typically, the heater is off while the air valve modulates primary air and responds to zone temperature. If zone temperature decreases to the point where a decrease in primary air will not maintain the desired temperature, the re-heat will be activated to increase the temperature of the discharge air.

On a parallel unit, the VariTrane air valve delivers primary cooling air to the unit outlet. When the space temperature decreases beyond air valve control, the fan is turned on as the first stage of heat. The fan delivers plenum air from above the occupied space to the unit outlet, which is mixed with primary air and delivered to the occupied space.

Note: Either the fan, the air valve, or both can deliver airflow into the occupied space. In order to prevent primary airflow from exiting through the fan when the fan is not running on a parallel unit, a back draft damper is provided. When the fan is not running, the efficiency of this system is the same as a standard single-duct VAV unit.

Typically, the control systems applied to parallel units cause the air valve to close to zero or a minimum flow before the fan is activated. After the fan is activated, the optional heat will be activated upon further reduction in zone temperature. Therefore, minimal primary air is mixed with the heated air.

VariTrane fan-powered unit fan sizes 02SQ–05SQ and 08SQ–10SQ were performance tested at .12 in. w.g. and sizes 06SQ and 07SQ were tested at .15 in. w.g. Units are not designed to operate unducted and below these tested static pressures.

Note: Fan-powered units are available with rectangular discharge connection only. The optional heater is mounted on the discharge of the unit. Hot water coils are connected to either the plenum inlet or on the discharge on parallel units, and to the discharge of series units.

Figure 3 – Typical Fan-Powered Units

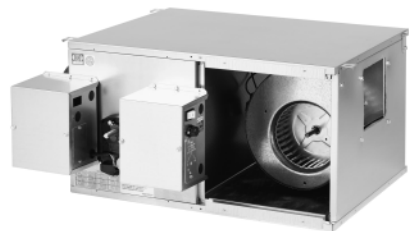

VSCF



VPCF



VSEF



VPEF

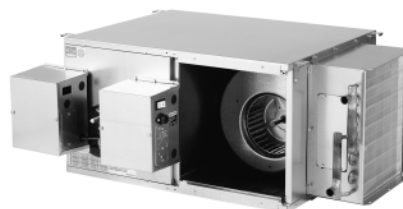

VSWF



VPWF

Unit Installation

Due to their weight, the VAV terminal units should be suspended from the uppermost ceiling, independent of the false ceiling grid. Suspension devices are to be supplied by the installer. Units must be installed level and upright. Failure to level the unit properly may prevent proper operation of the controls and/or terminal unit. Units are not designed to be installed vertically. Consequently, this will also void the UL ratings and any warranty on the unit.

Single-Duct

Depending upon the size and weight of the single-duct unit, it may be capable of being supported by the ductwork that is connected to it. No hanger brackets are provided on these units since the unit should be supported by means of a hanger strap. The hanger strap should be secured directly to the unit casing as shown in Figure 4.

For cooling only single-duct units or single-duct units with hot water coil, the unit may be rotated 180° for opposite side connections.

For units with electric heat, the unit must be ordered from the factory designating either right- or left-hand connections.

Figure 4

Single-Duct Hanging Recommendations

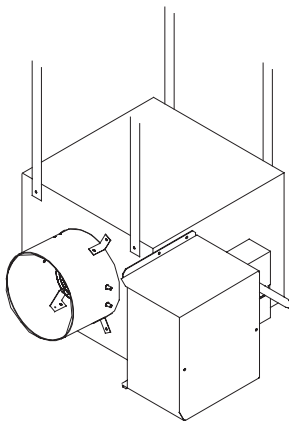

Dual-Duct

Dual-duct units should be supported by either hanger straps or by using a threaded rod in conjunction with the hanger brackets that are provided on the unit. See Figure 5.

Figure 5

Dual-Duct Hanger Bracket Locations

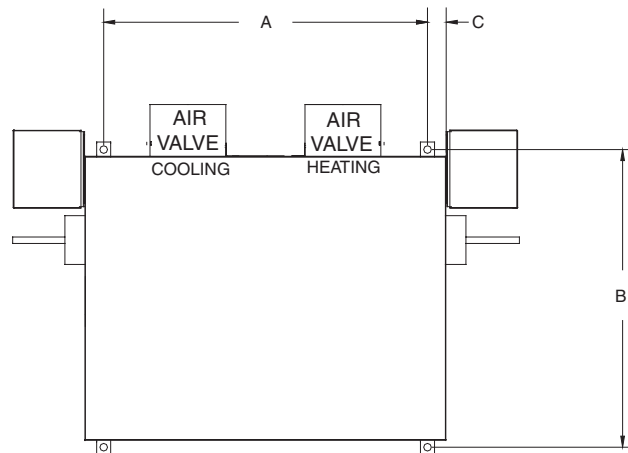

TOP VIEW

Inlet Size	A	B	C
5" thru 10"	23.154" (588 mm)	25.25" (641 mm)	1.376" (35 mm)
12" thru 16"	25.154" (639 mm)	37.25" (946 mm)	1.376" (35 mm)

Unit Installation

Fan-Powered (Standard and Low-Height)

Fan-powered units should be supported by either hanger straps or by using a threaded rod in conjunction with the hanger brackets that are provided on the unit. Care should be exercised to insure that the hanging straps do not block the side access panel. See Figures 6–13.

Figure 6

Parallel Hanger Bracket Locations Sizes

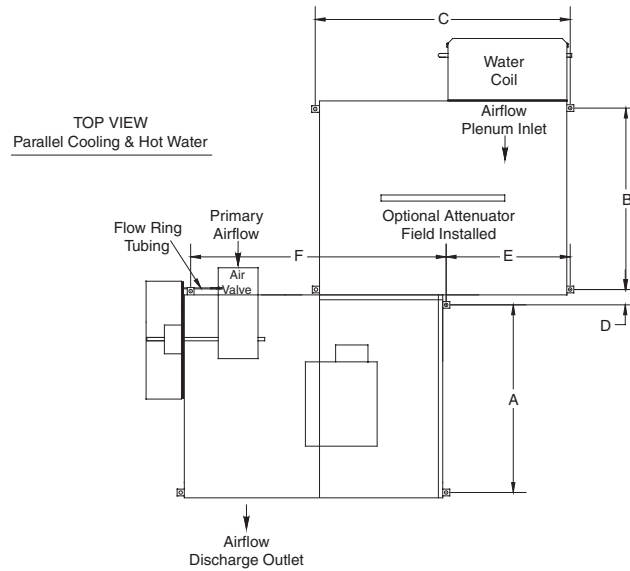

FAN SIZE	A	B	C	D	E	F
02SQ	26.75" (679 mm)	26.75" (679 mm)	41.154" (1041 mm)	3.25" (83 mm)	20.00" (508 mm)	38.95" (989 mm)
03SQ, 04SQ, 05SQ	29.75" (756 mm)	26.75" (679 mm)	41.154" (1041 mm)	3.25" (83 mm)	20.00" (508 mm)	38.95" (989 mm)
06SQ, 07SQ	36.75" (933 mm)	26.75" (679 mm)	41.154" (1041 mm)	3.25" (83 mm)	20.00" (508 mm)	38.95" (989 mm)

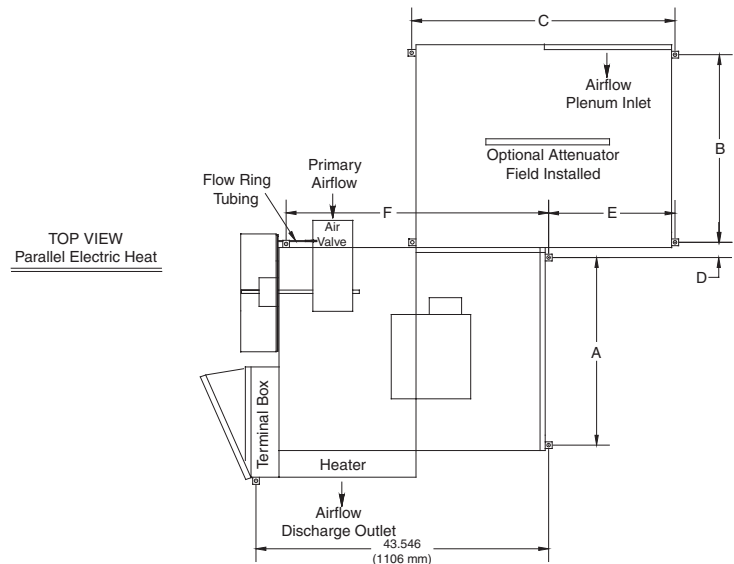

Unit Installation

Figure 7

Series Hanger Bracket Locations

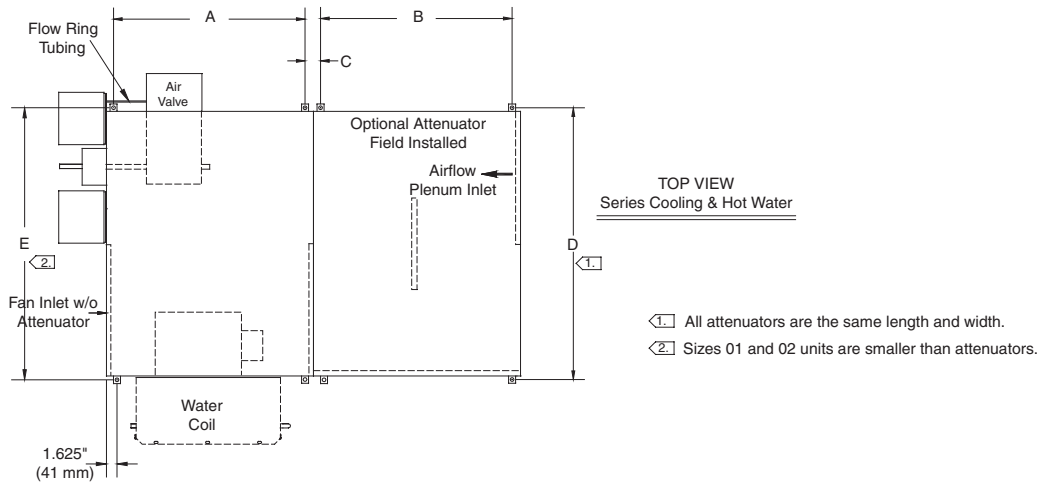

FAN SIZE	A	B	C	D	E	F (Elec. Heat Only)
02SQ	18.75" (476 mm)	26.75" (679 mm)	3.25" (83 mm)	41.154" (1041 mm)	35.154" (740 mm)	20.132" (511 mm)
03SQ, 04SQ	20.75" (527 mm)	26.75" (679 mm)	3.25" (83 mm)	41.154" (1041 mm)	41.154" (1041 mm)	23.875" (606 mm)
05SQ	27.25" (692 mm)	26.75" (679 mm)	3.25" (83 mm)	41.154" (1041 mm)	41.154" (1041 mm)	29.875" (759 mm)
06SQ, 07SQ	27.25" (692 mm)	26.75" (679 mm)	3.25" (83 mm)	41.154" (1041 mm)	41.154" (1041 mm)	29.875" (759 mm)

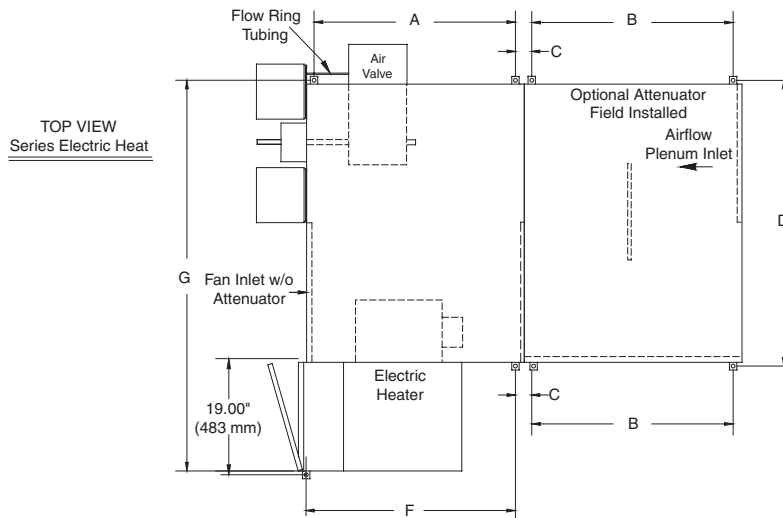

Unit Installation

Figure 8

Low-Height Parallel 08SQ/09SQ w/ Hot Water or Electric Heat

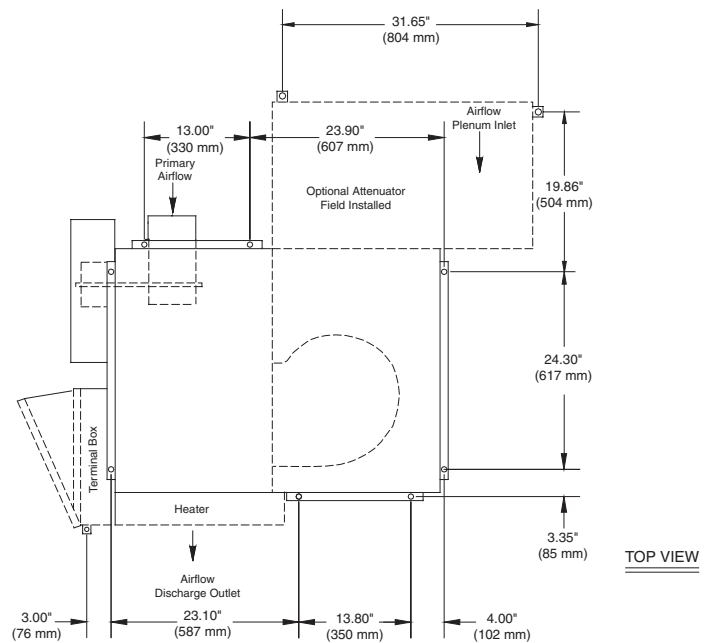
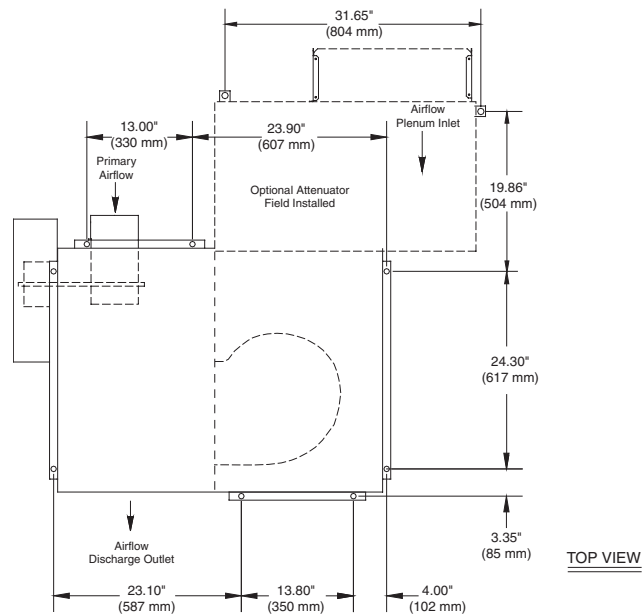

Unit Installation

Figure 9

Low-Height Parallel10SQ

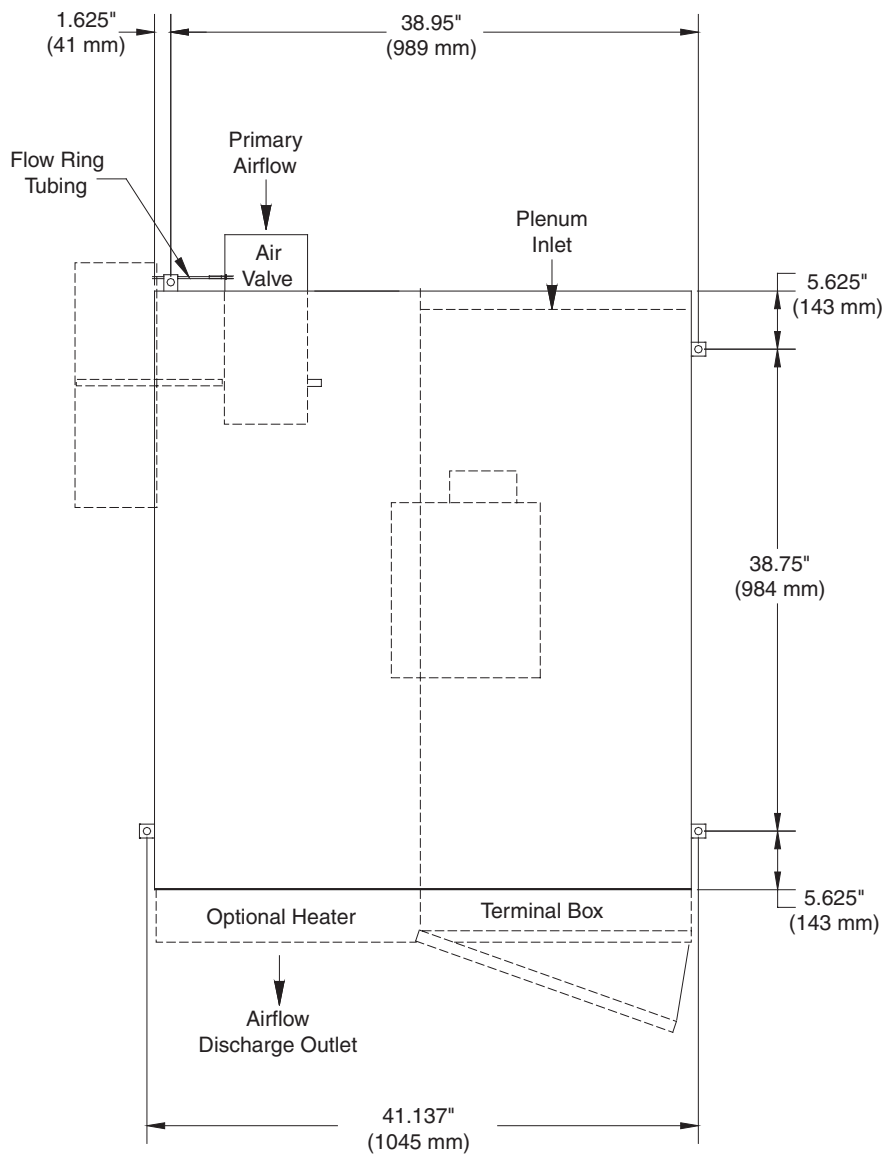

TOP VIEW

Unit Installation

Figure 10

Low-Height Series 08SQ/09SQ w/ Hot Water or Electric Heat

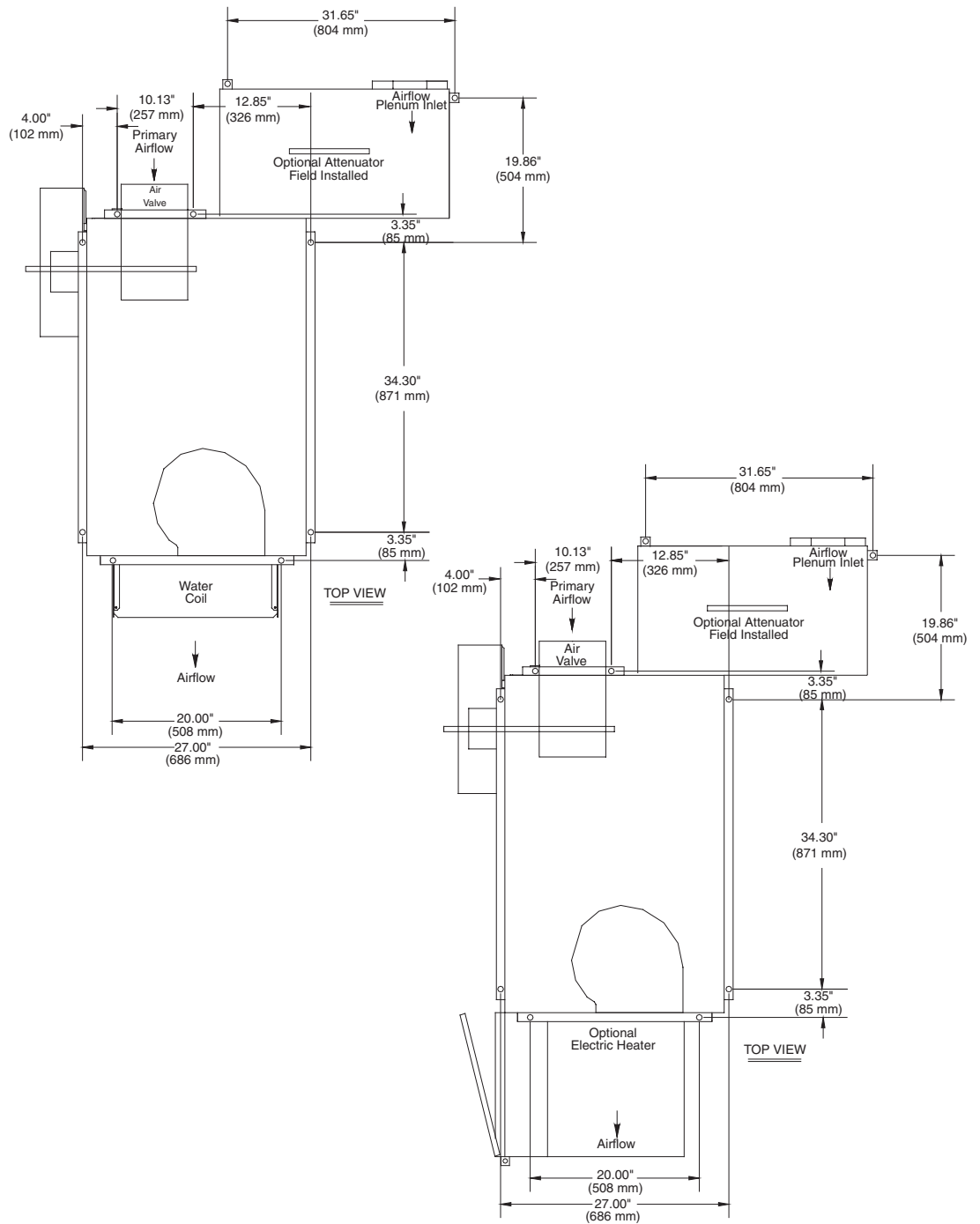

Unit Installation

Figure 11

Low-Height Series 10SQ w/ Hot Water or Electric Heat

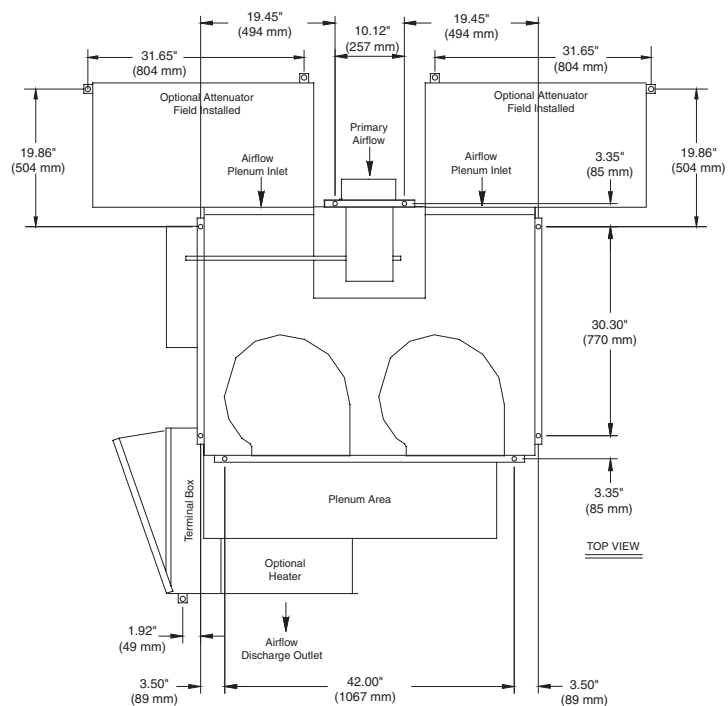
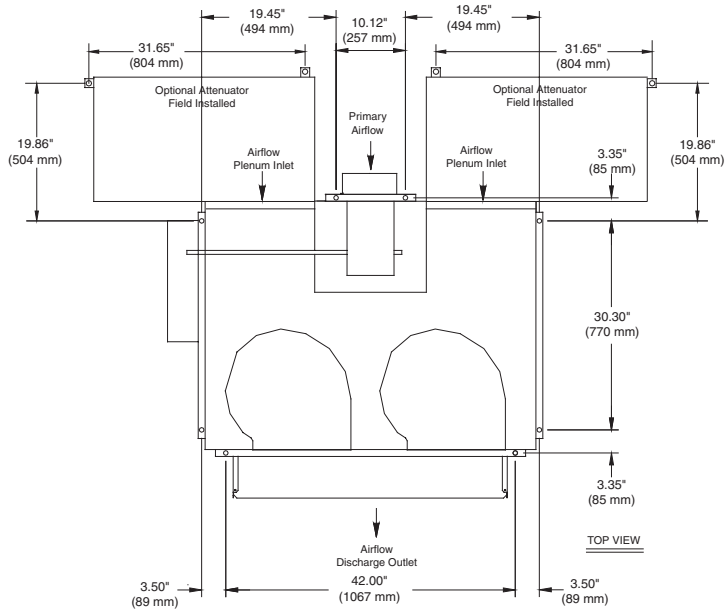

Unit Installation

Figure 12

Attenuator Installation—Parallel Units

1. Attach attenuator to unit as shown with provided mounting brackets.

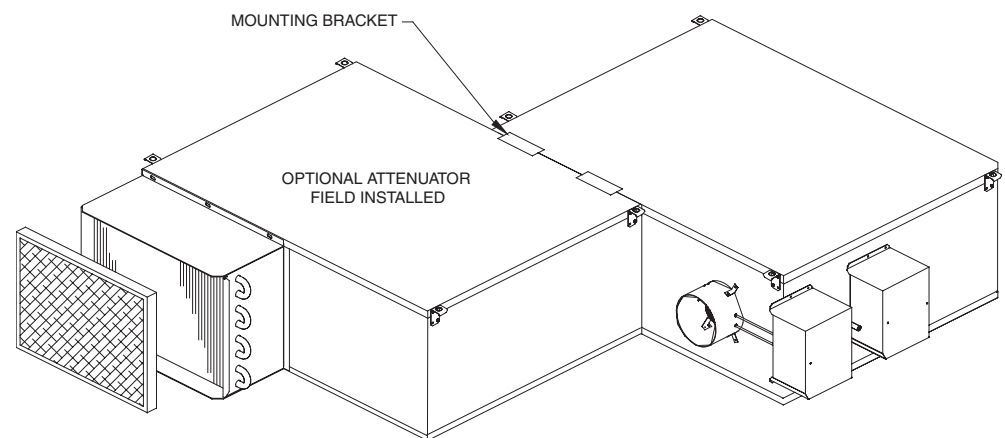

Note: Bottom bracket not shown. Bottom bracket to be installed in same orientation on bottom of unit.

Unit Installation

Figure 13

Attenuator Installation—Series Units

1. Attach attenuator to unit as shown with provided mounting brackets.

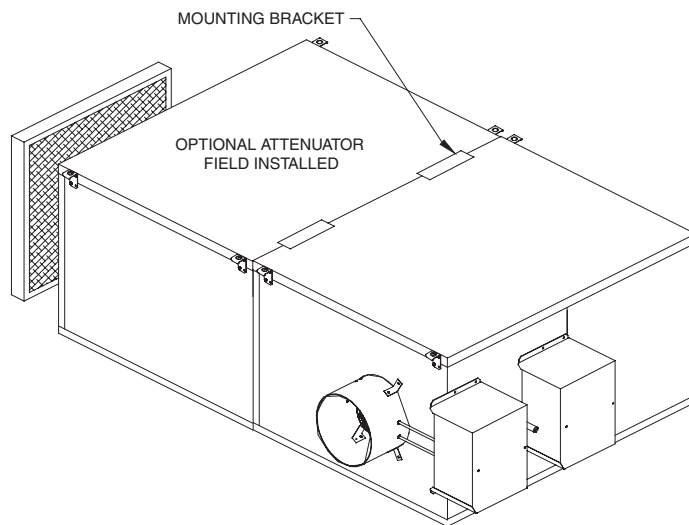

Note: Bottom bracket not shown. Bottom bracket to be installed in same orientation on bottom of unit.

Unit Installation

Figure 14

Attenuator Installation—Low-Height Parallel Units

1. Attach attenuator to unit as shown with provided mounting brackets.

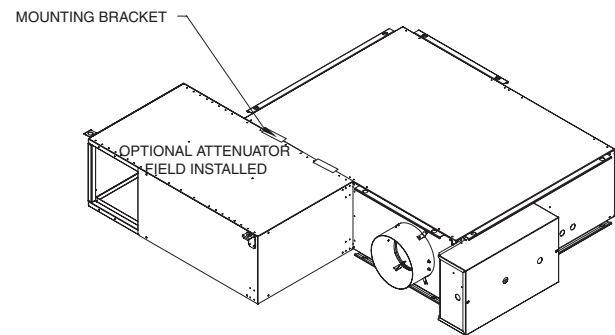

Note: Bottom bracket not shown. Bottom bracket to be installed in same orientation on bottom of unit.

Unit Installation

Figure 15

Attenuator Installation—Low-Height Series Units

1. Attach attenuator to unit as shown with provided mounting brackets.

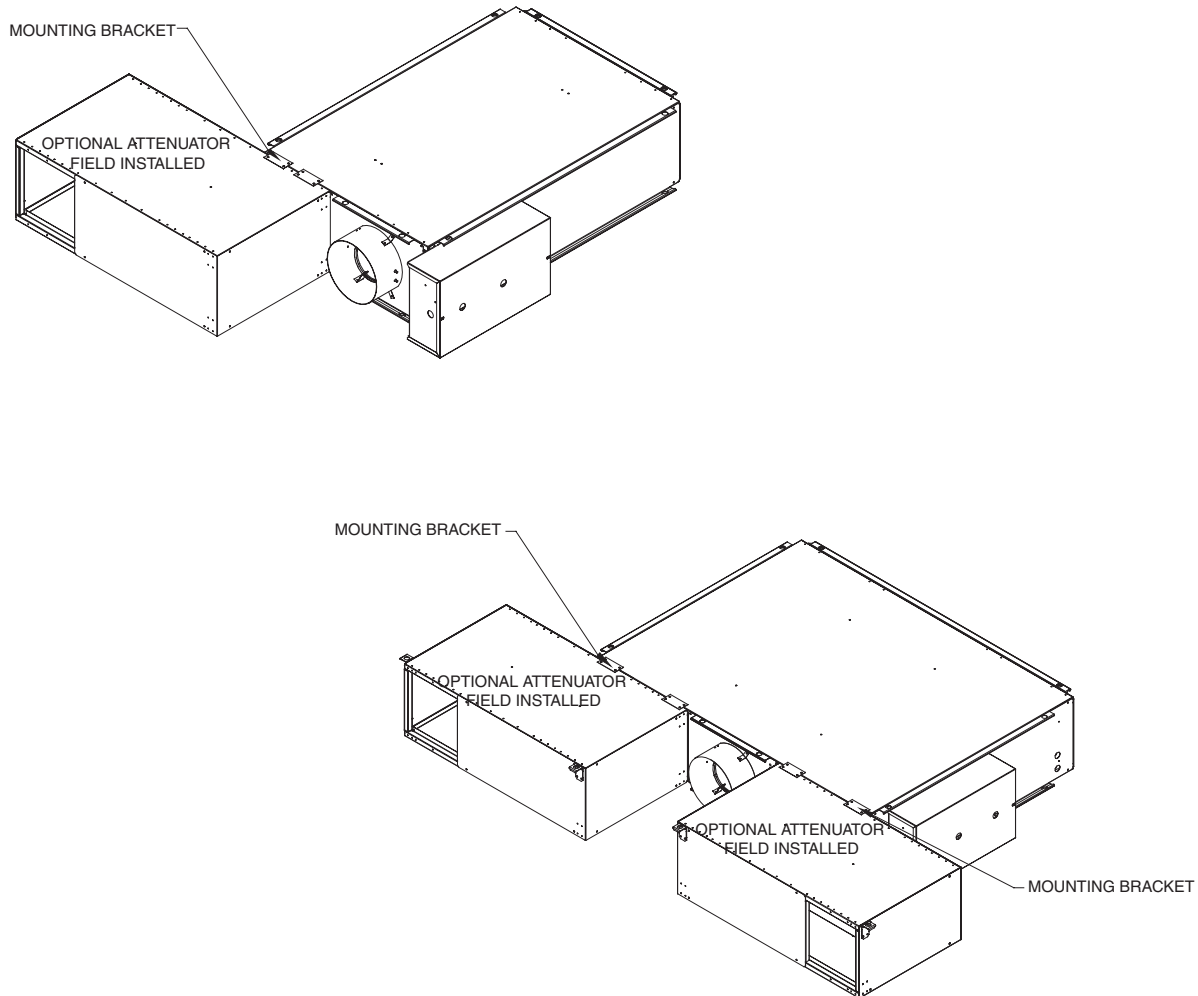

Note: Bottom bracket not shown. Bottom bracket to be installed in same orientation on bottom of unit.



Unit Installation

Chart 1 – Unit Weights

Single-Duct Units

Unit Size	VCCF (lbs/kg)	VCCF w/ Dual Wall (lbs/kg)	VCEF (lbs/kg)	VCEF w/ Dual Wall (lbs/kg)	VCWF 1-Row (lbs/kg)	VCWF 2-Row (lbs/kg)	VCWF 1-Row w/ Dual Wall (lbs/kg)	VCWF 2-Row w/ Dual Wall (lbs/kg)
4	16/7	19/9	38/17	48/22	21/10	22/10	24/11	25/11
5	16/7	19/9	38/17	48/22	21/10	22/10	24/11	25/11
6	16/7	19/9	38/17	48/22	21/10	22/10	24/11	25/11
8	16/7	20/9	38/17	49/22	21/10	24/11	25/11	28/13
10	22/10	27/12	46/21	60/27	29/13	32/15	34/15	37/17
12	27/12	34/15	52/24	68/31	37/17	40/18	43/20	47/21
14	32/15	41/19	60/27	80/36	44/20	48/22	53/24	57/26
16	35/16	46/21	69/31	91/41	49/22	54/24	60/27	65/29
24	52/24	63/29	84/38	106/48	70/32	77/35	81/37	88/40

Dual-Duct Units

Unit Size	VDDF (lbs/kg)	VDDF w/ Dual Wall (lbs/kg)
0505	54/24	68/31
0506	54/24	68/31
0606	54/24	68/31
0508	55/25	68/31
0608	55/25	69/31
0510	56/25	69/31
0808	56/25	70/32
0610	56/25	70/32
0810	57/26	70/32
1010	61/28	74/34
0612	57/26	70/32
0812	58/26	71/32

Unit Size	VDDF (lbs/kg)	VDDF w/ Dual Wall (lbs/kg)
1012	59/27	72/33
1212	60/27	84/38
0814	78/35	102/46
1014	79/36	103/47
1214	80/36	104/47
1414	81/37	105/48
0816	79/36	103/47
1016	80/36	104/47
1216	81/37	105/48
1416	82/37	105/48
1616	83/38	106/48

Parallel Fan-Powered Units

Unit Size	VPCF (lbs/kg)	VPCF w/ Dual Wall (lbs/kg)	VPEF (lbs/kg)	VPEF w/ Dual Wall (lbs/kg)	VPWF 1-Row (lbs/kg)	VPWF 2-Row (lbs/kg)	VPWF 1-Row w/ Dual Wall (lbs/kg)	VPWF 2-Row w/ Dual Wall (lbs/kg)	VPxF Attenuator (lbs/kg)
0502SQ	81/37	115/52	110/550	144/65	92/42	95/43	126/57	129/59	46/21
0602SQ	80/36	114/52	109/49	143/65	91/41	94/43	125/57	128/58	46/21
0603SQ	83/38	117/53	112/51	146/66	105/48	108/49	139/63	142/64	48/22
0802SQ	81/37	115/52	110/50	144/65	92/42	95/43	126/57	129/59	46/21
0803SQ	83/38	117/53	112/51	146/66	105/48	108/49	139/63	142/64	48/22
0804SQ	84/38	118/54	113/51	147/67	106/48	109/49	140/64	143/65	48/22
1002SQ	82/37	116/53	111/50	145/66	93/42	96/44	127/58	130/59	46/21
1003SQ	84/38	118/54	113/51	147/67	106/48	109/49	140/64	143/65	48/22
1004SQ	85/39	119/54	114/52	148/67	107/49	110/50	141/64	144/65	48/22
1005SQ	98/44	132/60	128/58	162/73	120/54	123/56	154/70	157/71	48/22
1006SQ	114/52	148/67	144/65	178/81	127/58	130/59	161/73	164/74	54/24
1007SQ	122/55	156/71	152/69	186/84	135/61	138/63	169/77	172/78	54/24
1203SQ	85/39	119/54	114/52	148/67	107/49	110/50	141/64	144/65	48/22
1204SQ	86/39	120/54	115/52	149/68	108/49	111/50	142/64	145/66	48/22
1205SQ	99/45	133/60	129/59	163/74	121/55	124/56	155/70	158/72	48/22
1206SQ	115/52	149/68	145/66	179/81	128/58	131/59	162/73	165/75	54/24
1207SQ	123/56	157/71	153/69	187/85	136/62	139/63	170/77	173/78	54/24
1404SQ	87/39	121/55	116/53	150/68	109/49	112/51	143/65	146/66	48/22
1405SQ	100/45	134/61	130/59	164/74	122/55	125/57	156/71	159/72	48/22
1406SQ	116/53	150/68	146/66	180/82	129/59	132/60	163/74	166/75	54/24
1407SQ	124/56	158/72	154/70	188/85	137/62	140/64	171/78	174/79	54/24
1606SQ	117/53	151/68	147/67	181/82	130/59	133/60	164/74	167/76	54/24
1607SQ	125/57	159/72	155/70	189/86	138/63	141/64	172/78	175/79	54/24



Unit Installation

Chart 1 – Unit Weights (Con't.)

Series Fan-Powered

Unit Size	VSCF (lbs/kg)	VSCF w/ DualWall (lbs/kg)	VSEF (lbs/kg)	VSEF w/ DualWall (lbs/kg)	VSWF 1-Row (lbs/kg)	VSWF 2-Row (lbs/kg)	VSWF 1-Row w/ DualWall (lbs/kg)	VSWF 2-Row w/ DualWall (lbs/kg)	VSxF Attenuator (lbs/kg)
0402SQ	78/35	93/42	104/47	119/54	85/39	87/39	100/45	102/46	46/21
0502SQ	78/35	93/42	104/47	119/54	85/39	87/39	100/45	102/46	46/21
0602SQ	77/35	92/42	103/47	118/54	84/38	86/39	99/45	101/46	46/21
0603SQ	76/34	100/45	105/48	129/59	88/40	92/42	112/51	116/53	48/22
0604SQ	87/39	111/50	116/53	140/64	99/45	103/47	123/56	127/58	48/22
0802SQ	79/36	94/43	105/48	120/54	86/39	88/40	101/46	103/47	46/21
0803SQ	77/35	101/46	106/48	130/59	89/40	93/42	113/51	117/53	48/22
0804SQ	88/40	112/51	117/53	141/64	100/45	104/47	124/56	128/58	48/22
1002SQ	81/37	96/44	107/49	122/55	88/40	90/41	103/47	105/48	46/21
1003SQ	80/36	104/47	109/49	133/60	92/42	96/44	116/53	120/54	48/22
1004SQ	91/41	115/52	120/54	144/65	103/47	107/49	127/58	131/59	48/22
1005SQ	92/42	116/53	121/55	145/66	104/47	108/49	128/58	132/60	48/22
1006SQ	104/47	133/60	135/61	164/74	119/54	124/56	148/67	153/69	54/24
1007SQ	117/53	146/66	148/67	177/80	132/60	137/62	161/73	166/75	54/24
1203SQ	82/37	106/48	111/50	135/61	94/43	98/44	118/54	122/55	48/22
1204SQ	92/42	116/53	121/55	145/66	104/47	108/49	128/58	132/60	48/22
1205SQ	94/43	118/54	123/56	147/67	106/48	110/50	130/59	134/61	48/22
1206SQ	105/48	134/61	136/62	165/75	120/54	125/57	149/68	154/70	54/24
1207SQ	118/54	147/67	149/68	178/81	133/60	138/63	162/73	167/76	54/24
1404SQ	93/42	117/53	122/55	146/66	105/48	109/49	129/59	133/60	48/22
1405SQ	96/44	120/54	125/57	149/68	108/49	112/51	132/60	136/62	48/22
1406SQ	106/48	135/61	137/62	166/75	121/55	126/57	150/68	155/70	54/24
1407SQ	119/54	148/67	150/68	179/81	134/61	139/63	163/74	168/76	54/24
1606SQ	107/49	136/62	138/63	167/76	122/55	127/58	151/68	156/71	54/24
1607SQ	120/54	149/68	151/68	180/82	135/61	140/64	164/74	169/77	54/24

Low-Height Parallel Units

Unit Size	LPCF (lbs/kg)	LPCF w/ DualWall (lbs/kg)	LPEF (lbs/kg)	LPEF w/ DualWall (lbs/kg)	LPWF 1-Row (lbs/kg)	LPWF 2-Row (lbs/kg)	LPWF 1-Row w/ DualWall (lbs/kg)	LPWF 2-Row w/ DualWall (lbs/kg)	LPxF Attenuator (lbs/kg)
0508SQ	69/31	89/40	84/38	104/47	78/35	81/37	98/44	101/46	10/5
0608SQ	68/31	88/40	83/38	103/47	77/35	80/36	97/44	100/45	10/5
0609SQ	73/33	93/42	88/40	108/49	82/37	85/39	102/46	105/48	10/5
0808SQ	69/31	89/40	84/38	104/47	78/35	81/37	98/44	101/46	10/5
0809SQ	74/34	94/43	89/40	109/49	83/38	86/39	103/47	106/48	10/5
0810SQ	90/41	110/50	105/48	125/57	99/45	102/46	119/54	122/55	10/5
14RT09SQ	83/38	103/47	98/44	118/54	92/42	95/43	112/51	115/52	10/5
14RT10SQ	97/44	117/53	112/51	132/60	106/48	109/49	126/57	129/59	10/5

Low-Height Series Units

Unit Size	LSCF (lbs/kg)	LSCF w/ DualWall (lbs/kg)	LSEF (lbs/kg)	LSEF w/ DualWall (lbs/kg)	LSWF 1-Row (lbs/kg)	LSWF 2-Row (lbs/kg)	LSWF 1-Row w/ DualWall (lbs/kg)	LSWF 2-Row w/ DualWall (lbs/kg)	LSxF Attenuator (lbs/kg)
0508SQ	71/32	86/39	86/39	101/45	80/36	82/37	95/43	97/44	10/5
0608SQ	70/32	85/39	85/39	100/45	79/36	81/37	94/43	96/44	10/5
0609SQ	80/36	95/43	95/43	110/50	89/40	91/41	104/47	106/48	10/5
0808SQ	71/32	86/39	86/39	101/46	80/36	82/37	95/43	97/44	10/5
0809SQ	81/37	96/44	96/44	111/50	90/41	92/42	105/48	107/49	10/5
0810SQ	95/43	120/54	120/54	145/66	111/50	115/52	136/62	140/64	20/9
14RT09SQ	90/41	105/48	105/48	120/54	99/45	101/46	114/52	116/53	10/5
14RT10SQ	105/48	130/59	130/59	155/70	121/55	125/57	146/66	150/68	20/9

Unit Installation

Duct Connections

All VariTrane units should be provided with a minimum of 1.5-duct diameters of straight duct prior to the inlet of the unit. It is recommended that at least 48 inches of straight duct be provided from the discharge of the units prior to any take-offs or transitions. **This is a requirement for electric heat fan-powered units used in applications with 100% downward discharge.**

Note: In order to maintain the UL rating for VariTrane electric coils, there must be four feet of straight unlined ductwork downstream of the reheat coil prior to any diffuser takeoffs.

After all connections are made, check that the entire ductwork system is airtight. In some high-pressure systems, duct sealer may be necessary.

Provide insulation around the entire inlet collar (all the way to the unit casing).

Use caution not to damage the flow tubes when making ductwork connections or insulating.

Cut "slits" in the insulation for the flow tubes and secure with duct tape.

If the unit is to be installed in a location with high humidity, external insulation around the heating coil should be installed as required.

Water Coil Connections

Water coil piping connections will be 3/8" or 7/8" OD.

If necessary, you can change the coil connection from left-handed to right-handed (and vice-versa) by disconnecting the coil from the unit and rotating the coil "like a steering wheel" 180°.

The inlet piping should always be connected to the bottom connection of the coil regardless of handedness.

Care should be taken to properly support the water coil piping connections while connecting the adjoining pipe.

It is recommended that piping to the water coil should be done after field-mounted controls, external insulation, and ductwork connections have been completed.

Do not connect water valve or pipe extensions to the water coil connections unless supported.

Unit Accessibility

Single-duct and dual-duct units provided with hot water reheat have an access panel located on the side of the water coil. All other single-duct and dual-duct units are provided without access, as all functioning components are external to the unit.

Fan-powered terminals are provided with a sliding side access.

Low-height terminal units have a removable bottom panel.

Clearances

For proper service, it is recommended that at least 36" of side clearance be provided to service and access single-duct and dual-duct terminal units.

Fan-powered VAV units have a plenum inlet that must be clear of obstructions. Allow at least 36" of clearance in front of the side access and plenum opening.

Low-height fan-powered terminals require the same plenum clearance requirement that applies to the standard fan-powered units. However the access to the internal components is located on the bottom of the unit.

It is also recommended that 6" of clearance be provided to the top and bottom of all the units.

Note: The minimum clearance for controls and heater controls should be 36" for all models except units with 575-volt electric heaters, which require 48" of clearance. NEC and/or local codes override all clearance requirements.

Actuator Mounting

Trane offers a factory-mounted actuator with a 90-second drive time. The actuator drives 1 degree per second. A field-installed actuator may be used if desired. The actuator shaft has a 1/2-inch diameter and is designed to travel clockwise to close the damper and counter-clockwise to open the damper. There is an indicator on the end of the actuator shaft that can be used to determine the position of the damper.

CAUTION

Equipment Damage

Note: When installing or replacing the actuator tighten the actuator set screw per the manufacturer's instructions. Failure to follow the manufacturer's specifications may result in unit malfunction.



Unit Setup

Chart 2 – Flow Sensor Delta P vs. Airflow Delivery

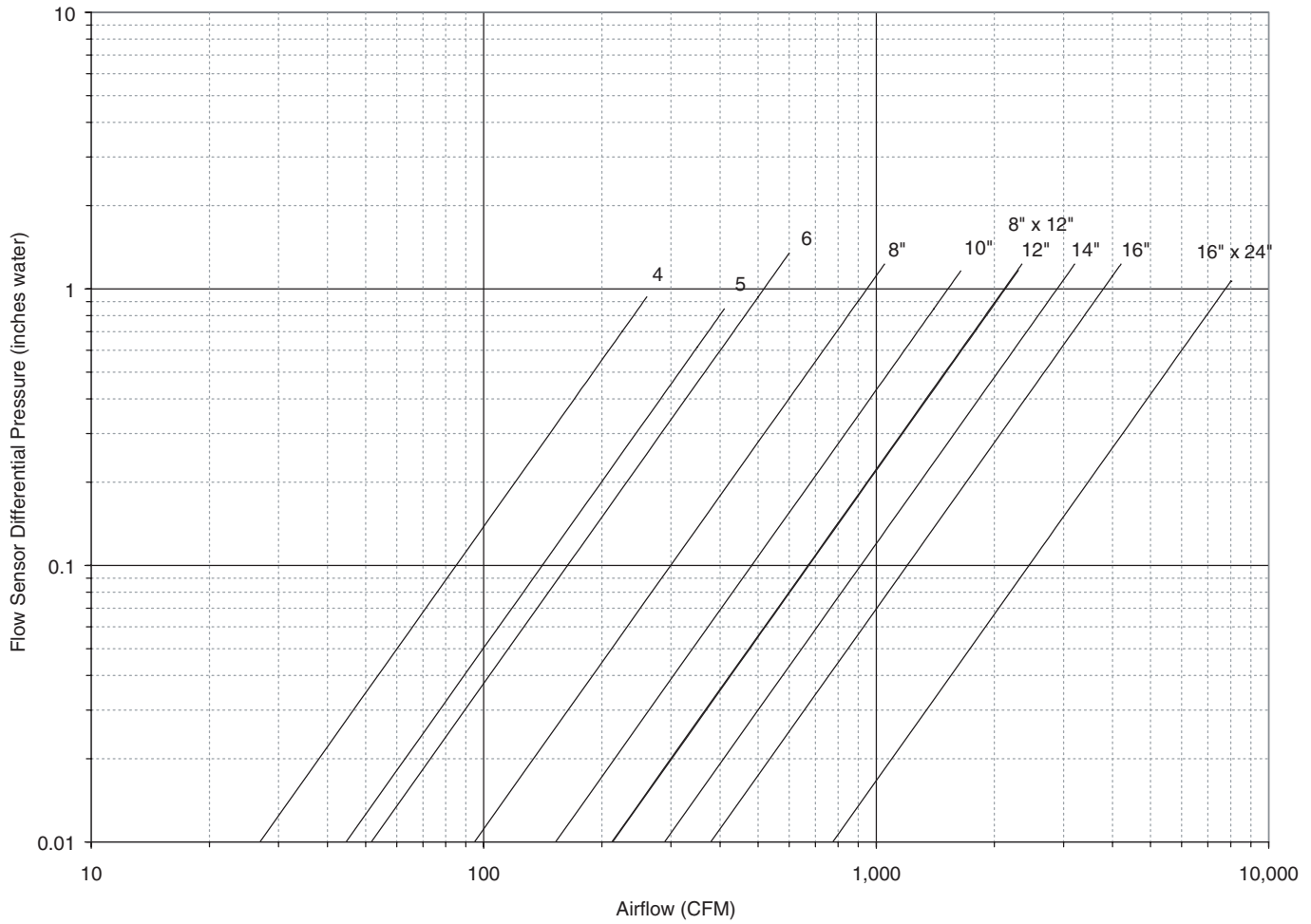

Chart 3– Fan Motor Amperage

Maximum PSC Fan Motor Amperage (FLA)

Fan Size	HP VAC	115 VAC	277 VAV	347 VAC	208
Parallel/Series 02SQ	1/8	1.6	0.7	.7	—
Parallel/Series 03SQ	1/3	4.3	1.6	1.4	—
Parallel/Series 04SQ	1/3	5.5	2.0	1.8	—
Parallel/Series 05SQ	1/2	6.7	2.4	2.2	—
Parallel/Series 06SQ	1/2	—	3.8	3.3	4.6
Parallel/Series 07SQ	1	—	4.7	3.8	6.6
Low-height Parallel/Series 08SQ	1/3	5.5	2.5	1.8	—
Low-height Parallel/Series 09SQ	1/3	5.5	2.5	1.8	—
Series Low-height 10SQ	2 x 1/8	11.0	5.0	3.5	—
Parallel Low-Height 10SQ	2 x 1/8	9.4	3.5	3.0	—

Maximum ECM Fan Motor Amperage (FLA)

Fan Size	HP VAC	115 VAC	277 VAV
Parallel/Series 03SQ	1/3	4.5	2.4
Parallel/Series 04SQ	1/2	6.5	3.5
Parallel/Series 05SQ	1	10.1	5.4
Parallel/Series 06SQ	1	9.5	5.1
Low-height Parallel/Series 08SQ	1/2	2.0	1.1
Low-height Parallel/Series 09SQ	1/2	6.7	3.6
Low-height Series 10SQ	2 x 1/2	7.5	4.0

Unit Setup

(SCR) Motor Speed Control Adjustment Procedure.

In order to make units more convenient and efficient to balance, an SCR (silicone control rectifier) is provided as standard on all fan-powered units.

The SCR is located on the side of the fan control box. To adjust the speed of the motor, the external knob must be rotated either clockwise or counterclockwise depending on the desired speed adjustment.

There is an internal potentiometer (Figure 14) setting on the SCR controller that can be accessed by removing the control box cover. This internal potentiometer is set at the factory to the specific motor voltage.

It may be necessary to adjust this in the field depending on the building's power factor.

⚠ WARNING

Hazardous Voltage!

Disconnect all electric power, including remote disconnects before servicing. Follow proper lockout/tagout procedures to ensure the power cannot be inadvertently energized. Failure to disconnect power before servicing could result in death or serious injury.

Figure 16 – SCR



Figure 17 – Internal Potentiometer

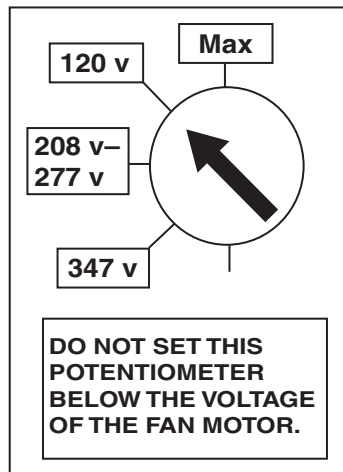

NOTE: Do not set this potentiometer below the voltage of the fan motor.

Electrically Commutated Motor (ECM)

Trane offers an energy efficient ECM motor as a motor option. Balancing of an ECM motor is accomplished through electronic control adjustments on the ECM control board (see Figure 15). Potentiometer settings for a multitude of CFM settings are given in Charts 4–15. Other potentiometer settings can be determined either by interpolating from these tables or by using the following equation:

$$\text{CFMsetting} = \text{CFMmin} + \{(\text{Potentiometer Setting}) \times [(\text{CFMmax} - \text{CFMmin})/100]\}$$

There is an LED on the ECM control board, which will blink one time for every 100 CFM of motor setting. For example, the LED on a unit set for 790 CFM will blink 7 times. The LED on a unit set for 800 CFM will blink 8 times.

NOTE: This feature only verifies that the CFM is set properly. This feature does not indicate at what speed the motor is actually running.

The ECM must be “load tested.” In other words, the fan must be connected to properly test the ECM.

Figure 18 – ECM Control Board

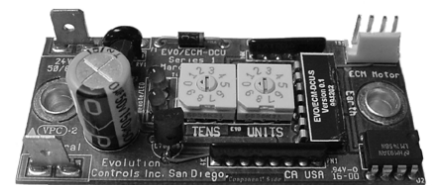



Unit Setup

Chart 4 – VPxF 03SQ ECM CFM Table

VPxF 03SQ

Motor Min CFM: 160
 Motor Max CFM: 1085

CFM	L/sec	% Setting	TENS Switch	UNITS Switch	CFM	% L/sec	TENS Setting	UNITS Switch	Switch
160	76	1	0	1	627	296	51	5	1
170	80	2	0	2	637	300	52	5	2
179	84	3	0	3	646	305	53	5	3
188	89	4	0	4	655	309	54	5	4
198	93	5	0	5	665	314	55	5	5
207	98	6	0	6	674	318	56	5	6
216	102	7	0	7	683	323	57	5	7
226	107	8	0	8	693	327	58	5	8
235	111	9	0	9	702	331	59	5	9
244	115	10	1	0	711	336	60	6	0
254	120	11	1	1	721	340	61	6	1
263	124	12	1	2	730	345	62	6	2
272	129	13	1	3	739	349	63	6	3
282	133	14	1	4	749	353	64	6	4
291	137	15	1	5	758	358	65	6	5
300	142	16	1	6	767	362	66	6	6
310	146	17	1	7	777	367	67	6	7
319	151	18	1	8	786	371	68	6	8
328	155	19	1	9	795	375	69	6	9
338	159	20	2	0	805	380	70	7	0
347	164	21	2	1	814	384	71	7	1
356	168	22	2	2	823	389	72	7	2
366	173	23	2	3	833	393	73	7	3
375	177	24	2	4	842	397	74	7	4
385	181	25	2	5	852	402	75	7	5
394	186	26	2	6	861	406	76	7	6
403	190	27	2	7	870	411	77	7	7
413	195	28	2	8	880	415	78	7	8
422	199	29	2	9	889	419	79	7	9
431	204	30	3	0	898	424	80	8	0
441	208	31	3	1	908	428	81	8	1
450	212	32	3	2	917	433	82	8	2
459	217	33	3	3	926	437	83	8	3
469	221	34	3	4	936	442	84	8	4
478	226	35	3	5	945	446	85	8	5
487	230	36	3	6	954	450	86	8	6
497	234	37	3	7	964	455	87	8	7
506	239	38	3	8	973	459	88	8	8
515	243	39	3	9	982	464	89	8	9
525	248	40	4	0	992	468	90	9	0
534	252	41	4	1	1001	472	91	9	1
543	256	42	4	2	1010	477	92	9	2
553	261	43	4	3	1020	481	93	9	3
562	265	44	4	4	1029	486	94	9	4
571	270	45	4	5	1038	490	95	9	5
581	274	46	4	6	1048	494	96	9	6
590	278	47	4	7	1057	499	97	9	7
599	283	48	4	8	1066	503	98	9	8
609	287	49	4	9	1076	508	99	9	9
618	292	50	5	0	1085	512	100	0	0

Unit Setup

Chart 5 – VPxF 04SQ ECM CFM Table

VPxF 04SQ

Motor Min CFM: 220

Motor Max CFM: 1510

CFM	L/sec	% Setting	TENS Switch	UNITS Switch	CFM	L/sec	% Setting	TENS Switch	UNITS Switch
220	104	1	0	1	872	411	51	5	1
233	110	2	0	2	885	417	52	5	2
246	116	3	0	3	898	424	53	5	3
259	122	4	0	4	911	430	54	5	4
272	128	5	0	5	924	436	55	5	5
285	135	6	0	6	937	442	56	5	6
298	141	7	0	7	950	448	57	5	7
311	147	8	0	8	963	454	58	5	8
324	153	9	0	9	976	461	59	5	9
337	159	10	1	0	989	467	60	6	0
350	165	11	1	1	1002	473	61	6	1
363	171	12	1	2	1015	479	62	6	2
376	178	13	1	3	1028	485	63	6	3
389	184	14	1	4	1041	491	64	6	4
402	190	15	1	5	1054	497	65	6	5
415	196	16	1	6	1067	504	66	6	6
429	202	17	1	7	1080	510	67	6	7
442	208	18	1	8	1093	516	68	6	8
455	215	19	1	9	1106	522	69	6	9
468	221	20	2	0	1119	528	70	7	0
481	227	21	2	1	1132	534	71	7	1
494	233	22	2	2	1145	540	72	7	2
507	239	23	2	3	1158	547	73	7	3
520	245	24	2	4	1171	553	74	7	4
533	251	25	2	5	1184	559	75	7	5
546	258	26	2	6	1197	565	76	7	6
559	264	27	2	7	1210	571	77	7	7
572	270	28	2	8	1223	577	78	7	8
585	276	29	2	9	1236	584	79	7	9
598	282	30	3	0	1249	590	80	8	0
611	288	31	3	1	1262	596	81	8	1
624	294	32	3	2	1275	602	82	8	2
637	301	33	3	3	1288	608	83	8	3
650	307	34	3	4	1302	614	84	8	4
663	313	35	3	5	1315	620	85	8	5
676	319	36	3	6	1328	627	86	8	6
689	325	37	3	7	1341	633	87	8	7
702	331	38	3	8	1354	639	88	8	8
715	338	39	3	9	1367	645	89	8	9
728	344	40	4	0	1380	651	90	9	0
741	350	41	4	1	1393	657	91	9	1
754	356	42	4	2	1406	663	92	9	2
767	362	43	4	3	1419	670	93	9	3
780	368	44	4	4	1432	676	94	9	4
793	374	45	4	5	1445	682	95	9	5
806	381	46	4	6	1458	688	96	9	6
819	387	47	4	7	1471	694	97	9	7
832	393	48	4	8	1484	700	98	9	8
845	399	49	4	9	1497	706	99	9	9
859	405	50	5	0	1510	713	100	0	0



Unit Setup

Chart 6 – VPxF 05SQ ECM CFM Table

VPxF 05SQ

Motor Min CFM: 280

Motor Max CFM: 1850

CFM	% L/sec	Setting	TENS Switch	UNITS Switch	CFM	L/Sec	% Setting	TENS Switch	UNITS Switch
280	132	1	0	1	1073	506	51	5	1
296	140	2	0	2	1089	514	52	5	2
312	147	3	0	3	1105	521	53	5	3
327	155	4	0	4	1120	529	54	5	4
343	162	5	0	5	1136	536	55	5	5
359	170	6	0	6	1152	544	56	5	6
375	177	7	0	7	1168	551	57	5	7
391	184	8	0	8	1184	559	58	5	8
407	192	9	0	9	1200	566	59	5	9
423	199	10	1	0	1216	574	60	6	0
438	207	11	1	1	1231	581	61	6	1
454	214	12	1	2	1247	589	62	6	2
470	222	13	1	3	1263	596	63	6	3
486	229	14	1	4	1279	604	64	6	4
502	237	15	1	5	1295	611	65	6	5
518	244	16	1	6	1311	619	66	6	6
534	252	17	1	7	1327	626	67	6	7
549	259	18	1	8	1342	634	68	6	8
565	267	19	1	9	1358	641	69	6	9
581	274	20	2	0	1374	649	70	7	0
597	282	21	2	1	1390	656	71	7	1
613	289	22	2	2	1406	664	72	7	2
629	297	23	2	3	1422	671	73	7	3
645	304	24	2	4	1438	678	74	7	4
661	312	25	2	5	1454	686	75	7	5
676	319	26	2	6	1469	693	76	7	6
692	327	27	2	7	1485	701	77	7	7
708	334	28	2	8	1501	708	78	7	8
724	342	29	2	9	1517	716	79	7	9
740	349	30	3	0	1533	723	80	8	0
756	357	31	3	1	1549	731	81	8	1
772	364	32	3	2	1565	738	82	8	2
787	372	33	3	3	1580	746	83	8	3
803	379	34	3	4	1596	753	84	8	4
819	387	35	3	5	1612	761	85	8	5
835	394	36	3	6	1628	768	86	8	6
851	402	37	3	7	1644	776	87	8	7
867	409	38	3	8	1660	783	88	8	8
883	417	39	3	9	1676	791	89	8	9
898	424	40	4	0	1691	798	90	9	0
914	431	41	4	1	1707	806	91	9	1
930	439	42	4	2	1723	813	92	9	2
946	446	43	4	3	1739	821	93	9	3
962	454	44	4	4	1755	828	94	9	4
978	461	45	4	5	1771	836	95	9	5
994	469	46	4	6	1787	843	96	9	6
1009	476	47	4	7	1802	851	97	9	7
1025	484	48	4	8	1818	858	98	9	8
1041	491	49	4	9	1834	866	99	9	9
1057	499	50	5	0	1850	873	100	0	0



Unit Setup

Chart 7 – VPxF 06SQ ECM CFM Table

VPxF 06SQ

Motor Min CFM: 530

Motor Max CFM: 2100

CFM	% L/sec	TENS Setting	UNITS Switch	Switch	CFM	% L/sec	TENS Setting	UNITS Switch	Switch
530	250	1	0	1	1323	624	51	5	1
546	258	2	0	2	1339	632	52	5	2
562	265	3	0	3	1355	639	53	5	3
577	273	4	0	4	1370	647	54	5	4
593	280	5	0	5	1386	654	55	5	5
609	287	6	0	6	1402	662	56	5	6
625	295	7	0	7	1418	669	57	5	7
641	302	8	0	8	1434	677	58	5	8
657	310	9	0	9	1450	684	59	5	9
673	317	10	1	0	1466	692	60	6	0
688	325	11	1	1	1481	699	61	6	1
704	332	12	1	2	1497	707	62	6	2
720	340	13	1	3	1513	714	63	6	3
736	347	14	1	4	1529	722	64	6	4
752	355	15	1	5	1545	729	65	6	5
768	362	16	1	6	1561	737	66	6	6
784	370	17	1	7	1577	744	67	6	7
799	377	18	1	8	1592	752	68	6	8
815	385	19	1	9	1608	759	69	6	9
831	392	20	2	0	1624	767	70	7	0
847	400	21	2	1	1640	774	71	7	1
863	407	22	2	2	1656	782	72	7	2
879	415	23	2	3	1672	789	73	7	3
895	422	24	2	4	1688	796	74	7	4
911	430	25	2	5	1704	804	75	7	5
926	437	26	2	6	1719	811	76	7	6
942	445	27	2	7	1735	819	77	7	7
958	452	28	2	8	1751	826	78	7	8
974	460	29	2	9	1767	834	79	7	9
990	467	30	3	0	1783	841	80	8	0
1006	475	31	3	1	1799	849	81	8	1
1022	482	32	3	2	1815	856	82	8	2
1037	490	33	3	3	1830	864	83	8	3
1053	497	34	3	4	1846	871	84	8	4
1069	505	35	3	5	1862	879	85	8	5
1085	512	36	3	6	1878	886	86	8	6
1101	520	37	3	7	1894	894	87	8	7
1117	527	38	3	8	1910	901	88	8	8
1133	535	39	3	9	1926	909	89	8	9
1148	542	40	4	0	1941	916	90	9	0
1164	549	41	4	1	1957	924	91	9	1
1180	557	42	4	2	1973	931	92	9	2
1196	564	43	4	3	1989	939	93	9	3
1212	572	44	4	4	2005	946	94	9	4
1228	579	45	4	5	2021	954	95	9	5
1244	587	46	4	6	2037	961	96	9	6
1259	594	47	4	7	2052	969	97	9	7
1275	602	48	4	8	2068	976	98	9	8
1291	609	49	4	9	2084	984	99	9	9
1307	617	50	5	0	2100	991	100	0	0



Unit Setup

Chart 8 – VSxF 03SQ ECM CFM Table

VSxF 03SQ

Motor Min CFM: 200
 Motor Max CFM: 1100

CFM	L/sec	% Setting	TENS Switch	UNITS Switch
200	94	1	0	1
209	99	2	0	2
218	103	3	0	3
227	107	4	0	4
236	112	5	0	5
246	116	6	0	6
255	120	7	0	7
264	124	8	0	8
273	129	9	0	9
282	133	10	1	0
291	137	11	1	1
300	142	12	1	2
309	146	13	1	3
318	150	14	1	4
327	154	15	1	5
336	159	16	1	6
346	163	17	1	7
355	167	18	1	8
364	172	19	1	9
373	176	20	2	0
382	180	21	2	1
391	185	22	2	2
400	189	23	2	3
409	193	24	2	4
418	197	25	2	5
427	202	26	2	6
436	206	27	2	7
446	210	28	2	8
455	215	29	2	9
464	219	30	3	0
473	223	31	3	1
482	227	32	3	2
491	232	33	3	3
500	236	34	3	4
509	240	35	3	5
518	245	36	3	6
527	249	37	3	7
536	253	38	3	8
546	257	39	3	9
555	262	40	4	0
564	266	41	4	1
573	270	42	4	2
582	275	43	4	3
591	279	44	4	4
600	283	45	4	5
609	287	46	4	6
618	292	47	4	7
627	296	48	4	8
636	300	49	4	9
646	305	50	5	0

CFM	L/sec	% Setting	TENS Switch	UNITS Switch
655	309	51	5	1
664	313	52	5	2
673	318	53	5	3
682	322	54	5	4
691	326	55	5	5
700	330	56	5	6
709	335	57	5	7
718	339	58	5	8
727	343	59	5	9
736	348	60	6	0
745	352	61	6	1
755	356	62	6	2
764	360	63	6	3
773	365	64	6	4
782	369	65	6	5
791	373	66	6	6
800	378	67	6	7
809	382	68	6	8
818	386	69	6	9
827	390	70	7	0
836	395	71	7	1
845	399	72	7	2
855	403	73	7	3
864	408	74	7	4
873	412	75	7	5
882	416	76	7	6
891	420	77	7	7
900	425	78	7	8
909	429	79	7	9
918	433	80	8	0
927	438	81	8	1
936	442	82	8	2
945	446	83	8	3
955	451	84	8	4
964	455	85	8	5
973	459	86	8	6
982	463	87	8	7
991	468	88	8	8
1000	472	89	8	9
1009	476	90	9	0
1018	481	91	9	1
1027	485	92	9	2
1036	489	93	9	3
1045	493	94	9	4
1055	498	95	9	5
1064	502	96	9	6
1073	506	97	9	7
1082	511	98	9	8
1091	515	99	9	9
1100	519	100	0	0

Unit Setup

Chart 9– VSxF 04SQ ECM CFM Table

VSxF 04SQ

Motor Min CFM: 275

Motor Max CFM: 1500

CFM	% L/sec	TENS Setting	UNITS Switch	Switch	CFM	L/sec	% Setting	TENS Switch	UNITS Switch
275	130	1	0	1	894	422	51	5	1
288	136	2	0	2	906	428	52	5	2
300	142	3	0	3	919	434	53	5	3
312	147	4	0	4	931	439	54	5	4
325	153	5	0	5	943	445	55	5	5
337	159	6	0	6	956	451	56	5	6
350	165	7	0	7	968	457	57	5	7
362	171	8	0	8	980	463	58	5	8
374	177	9	0	9	993	469	59	5	9
387	183	10	1	0	1005	474	60	6	0
399	188	11	1	1	1018	480	61	6	1
411	194	12	1	2	1030	486	62	6	2
424	200	13	1	3	1042	492	63	6	3
436	206	14	1	4	1055	498	64	6	4
449	212	15	1	5	1067	504	65	6	5
461	218	16	1	6	1079	509	66	6	6
473	223	17	1	7	1092	515	67	6	7
486	229	18	1	8	1104	521	68	6	8
498	235	19	1	9	1117	527	69	6	9
510	241	20	2	0	1129	533	70	7	0
523	247	21	2	1	1141	539	71	7	1
535	253	22	2	2	1154	544	72	7	2
548	258	23	2	3	1166	550	73	7	3
560	264	24	2	4	1178	556	74	7	4
572	270	25	2	5	1191	562	75	7	5
585	276	26	2	6	1203	568	76	7	6
597	282	27	2	7	1215	574	77	7	7
609	288	28	2	8	1228	579	78	7	8
622	293	29	2	9	1240	585	79	7	9
634	299	30	3	0	1253	591	80	8	0
646	305	31	3	1	1265	597	81	8	1
659	311	32	3	2	1277	603	82	8	2
671	317	33	3	3	1290	609	83	8	3
684	323	34	3	4	1302	615	84	8	4
696	328	35	3	5	1314	620	85	8	5
708	334	36	3	6	1327	626	86	8	6
721	340	37	3	7	1339	632	87	8	7
733	346	38	3	8	1352	638	88	8	8
745	352	39	3	9	1364	644	89	8	9
758	358	40	4	0	1376	650	90	9	0
770	363	41	4	1	1389	655	91	9	1
783	369	42	4	2	1401	661	92	9	2
795	375	43	4	3	1413	667	93	9	3
807	381	44	4	4	1426	673	94	9	4
820	387	45	4	5	1438	679	95	9	5
832	393	46	4	6	1451	685	96	9	6
844	399	47	4	7	1463	690	97	9	7
857	404	48	4	8	1475	696	98	9	8
869	410	49	4	9	1488	702	99	9	9
882	416	50	5	0	1500	708	100	0	0



Unit Setup

Chart 10– VSxF 05SQ ECM CFM Table

VSxF 05SQ

Motor Min CFM: 350

Motor Max CFM: 2050

CFM	L/sec	% Setting	TENS Switch	UNITS Switch
350	165	1	0	1
367	173	2	0	2
385	181	3	0	3
402	190	4	0	4
419	198	5	0	5
436	206	6	0	6
453	214	7	0	7
470	222	8	0	8
488	230	9	0	9
505	238	10	1	0
522	246	11	1	1
539	254	12	1	2
556	263	13	1	3
573	271	14	1	4
591	279	15	1	5
608	287	16	1	6
625	295	17	1	7
642	303	18	1	8
659	311	19	1	9
676	319	20	2	0
694	327	21	2	1
711	335	22	2	2
728	344	23	2	3
745	352	24	2	4
762	360	25	2	5
779	368	26	2	6
797	376	27	2	7
814	384	28	2	8
831	392	29	2	9
848	400	30	3	0
865	408	31	3	1
882	416	32	3	2
900	425	33	3	3
917	433	34	3	4
934	441	35	3	5
951	449	36	3	6
968	457	37	3	7
985	465	38	3	8
1003	473	39	3	9
1020	481	40	4	0
1037	489	41	4	1
1054	498	42	4	2
1071	506	43	4	3
1088	514	44	4	4
1106	522	45	4	5
1123	530	46	4	6
1140	538	47	4	7
1157	546	48	4	8
1174	554	49	4	9
1192	562	50	5	0

CFM	L/sec	% Setting	TENS Switch	UNITS Switch
1209	570	51	5	1
1226	579	52	5	2
1243	587	53	5	3
1260	595	54	5	4
1277	603	55	5	5
1295	611	56	5	6
1312	619	57	5	7
1329	627	58	5	8
1346	635	59	5	9
1363	643	60	6	0
1380	651	61	6	1
1398	660	62	6	2
1415	668	63	6	3
1432	676	64	6	4
1449	684	65	6	5
1466	692	66	6	6
1483	700	67	6	7
1501	708	68	6	8
1518	716	69	6	9
1535	724	70	7	0
1552	732	71	7	1
1569	741	72	7	2
1586	749	73	7	3
1604	757	74	7	4
1621	765	75	7	5
1638	773	76	7	6
1655	781	77	7	7
1672	789	78	7	8
1689	797	79	7	9
1707	805	80	8	0
1724	814	81	8	1
1741	822	82	8	2
1758	830	83	8	3
1775	838	84	8	4
1792	846	85	8	5
1810	854	86	8	6
1827	862	87	8	7
1844	870	88	8	8
1861	878	89	8	9
1878	886	90	9	0
1895	895	91	9	1
1913	903	92	9	2
1930	911	93	9	3
1947	919	94	9	4
1964	927	95	9	5
1981	935	96	9	6
1998	943	97	9	7
2016	951	98	9	8
2033	959	99	9	9
2050	967	100	0	0

Unit Setup

Chart 11–VSxF 06SQ ECM CFM Table

VSxF 06SQ

Motor Min CFM: 700

Motor Max CFM: 2500

CFM	% L/sec	TENS Setting	UNITS Switch	Switch
700	330	1	0	1
718	339	2	0	2
737	348	3	0	3
755	356	4	0	4
773	365	5	0	5
791	373	6	0	6
809	382	7	0	7
827	391	8	0	8
846	399	9	0	9
864	408	10	1	0
882	416	11	1	1
900	425	12	1	2
918	433	13	1	3
937	442	14	1	4
955	451	15	1	5
973	459	16	1	6
991	468	17	1	7
1009	476	18	1	8
1027	485	19	1	9
1046	493	20	2	0
1064	502	21	2	1
1082	511	22	2	2
1100	519	23	2	3
1118	528	24	2	4
1137	536	25	2	5
1155	545	26	2	6
1173	554	27	2	7
1191	562	28	2	8
1209	571	29	2	9
1227	579	30	3	0
1246	588	31	3	1
1264	596	32	3	2
1282	605	33	3	3
1300	614	34	3	4
1318	622	35	3	5
1336	631	36	3	6
1355	639	37	3	7
1373	648	38	3	8
1391	656	39	3	9
1409	665	40	4	0
1427	674	41	4	1
1446	682	42	4	2
1464	691	43	4	3
1482	699	44	4	4
1500	708	45	4	5
1518	717	46	4	6
1536	725	47	4	7
1555	734	48	4	8
1573	742	49	4	9
1591	751	50	5	0

CFM	% L/sec	TENS Setting	UNITS Switch	Switch
1609	759	51	5	1
1627	768	52	5	2
1646	777	53	5	3
1664	785	54	5	4
1682	794	55	5	5
1700	802	56	5	6
1718	811	57	5	7
1736	820	58	5	8
1755	828	59	5	9
1773	837	60	6	0
1791	845	61	6	1
1809	854	62	6	2
1827	862	63	6	3
1846	871	64	6	4
1864	880	65	6	5
1882	888	66	6	6
1900	897	67	6	7
1918	905	68	6	8
1936	914	69	6	9
1955	922	70	7	0
1973	931	71	7	1
1991	940	72	7	2
2009	948	73	7	3
2027	957	74	7	4
2046	965	75	7	5
2064	974	76	7	6
2082	983	77	7	7
2100	991	78	7	8
2118	1000	79	7	9
2136	1008	80	8	0
2155	1017	81	8	1
2173	1025	82	8	2
2191	1034	83	8	3
2209	1043	84	8	4
2227	1051	85	8	5
2245	1060	86	8	6
2264	1068	87	8	7
2282	1077	88	8	8
2300	1085	89	8	9
2318	1094	90	9	0
2336	1103	91	9	1
2355	1111	92	9	2
2373	1120	93	9	3
2391	1128	94	9	4
2409	1137	95	9	5
2427	1146	96	9	6
2445	1154	97	9	7
2464	1163	98	9	8
2482	1171	99	9	9
2500	1180	100	0	0



Unit Setup

Chart 12- LPxF 08SQ ECM CFM Table

LPxF 08SQ

Motor Min CFM: 100

Motor Max CFM: 460

CFM	L/sec	% Setting	TENS Switch	UNITS Switch
100	47	1	0	1
103	49	2	0	2
107	50	3	0	3
111	52	4	0	4
114	54	5	0	5
118	56	6	0	6
121	57	7	0	7
125	59	8	0	8
129	61	9	0	9
132	62	10	1	0
136	64	11	1	1
140	66	12	1	2
143	68	13	1	3
147	69	14	1	4
151	71	15	1	5
154	73	16	1	6
158	75	17	1	7
162	76	18	1	8
165	78	19	1	9
169	80	20	2	0
172	81	21	2	1
176	83	22	2	2
180	85	23	2	3
183	87	24	2	4
187	88	25	2	5
191	90	26	2	6
194	92	27	2	7
198	93	28	2	8
202	95	29	2	9
205	97	30	3	0
209	99	31	3	1
212	100	32	3	2
216	102	33	3	3
220	104	34	3	4
223	105	35	3	5
227	107	36	3	6
231	109	37	3	7
234	111	38	3	8
238	112	39	3	9
242	114	40	4	0
245	116	41	4	1
249	117	42	4	2
253	119	43	4	3
256	121	44	4	4
260	123	45	4	5
263	124	46	4	6
267	126	47	4	7
271	128	48	4	8
274	129	49	4	9
278	131	50	5	0

CFM	L/sec	% Setting	TENS Switch	UNITS Switch
282	133	51	5	1
285	135	52	5	2
289	136	53	5	3
293	138	54	5	4
296	140	55	5	5
300	142	56	5	6
303	143	57	5	7
307	145	58	5	8
311	147	59	5	9
314	148	60	6	0
318	150	61	6	1
322	152	62	6	2
325	154	63	6	3
329	155	64	6	4
333	157	65	6	5
336	159	66	6	6
340	160	67	6	7
344	162	68	6	8
347	164	69	6	9
351	166	70	7	0
354	167	71	7	1
358	169	72	7	2
362	171	73	7	3
365	172	74	7	4
369	174	75	7	5
373	176	76	7	6
376	178	77	7	7
380	179	78	7	8
384	181	79	7	9
387	183	80	8	0
391	184	81	8	1
394	186	82	8	2
398	188	83	8	3
402	190	84	8	4
405	191	85	8	5
409	193	86	8	6
413	195	87	8	7
416	196	88	8	8
420	198	89	8	9
424	200	90	9	0
427	202	91	9	1
431	203	92	9	2
435	205	93	9	3
438	207	94	9	4
442	209	95	9	5
445	210	96	9	6
449	212	97	9	7
453	214	98	9	8
456	215	99	9	9
460	217	100	0	0

Unit Setup

Chart 13– LPxF 09SQ ECM CFM Table

LPxF 09SQ

Motor Min CFM: 250

Motor Max CFM: 1025

CFM	% L/sec	TENS Setting	UNITS Switch	Switch
250	118	1	0	1
258	122	2	0	2
265	125	3	0	3
273	129	4	0	4
281	133	5	0	5
289	136	6	0	6
297	140	7	0	7
305	144	8	0	8
312	147	9	0	9
320	151	10	1	0
328	155	11	1	1
336	159	12	1	2
344	162	13	1	3
352	166	14	1	4
359	170	15	1	5
367	173	16	1	6
375	177	17	1	7
383	181	18	1	8
391	184	19	1	9
399	188	20	2	0
406	192	21	2	1
414	196	22	2	2
422	199	23	2	3
430	203	24	2	4
438	207	25	2	5
446	210	26	2	6
453	214	27	2	7
461	218	28	2	8
469	221	29	2	9
477	225	30	3	0
485	229	31	3	1
493	232	32	3	2
500	236	33	3	3
508	240	34	3	4
516	244	35	3	5
524	247	36	3	6
532	251	37	3	7
540	255	38	3	8
547	258	39	3	9
555	262	40	4	0
563	266	41	4	1
571	269	42	4	2
579	273	43	4	3
587	277	44	4	4
594	281	45	4	5
602	284	46	4	6
610	288	47	4	7
618	292	48	4	8
626	295	49	4	9
634	299	50	5	0

CFM	L/sec	% Setting	TENS Switch	UNITS Switch
641	303	51	5	1
649	306	52	5	2
657	310	53	5	3
665	314	54	5	4
673	317	55	5	5
680	321	56	5	6
688	325	57	5	7
696	329	58	5	8
704	332	59	5	9
712	336	60	6	0
720	340	61	6	1
727	343	62	6	2
735	347	63	6	3
743	351	64	6	4
751	354	65	6	5
759	358	66	6	6
767	362	67	6	7
774	365	68	6	8
782	369	69	6	9
790	373	70	7	0
798	377	71	7	1
806	380	72	7	2
814	384	73	7	3
821	388	74	7	4
829	391	75	7	5
837	395	76	7	6
845	399	77	7	7
853	402	78	7	8
861	406	79	7	9
868	410	80	8	0
876	414	81	8	1
884	417	82	8	2
892	421	83	8	3
900	425	84	8	4
908	428	85	8	5
915	432	86	8	6
923	436	87	8	7
931	439	88	8	8
939	443	89	8	9
947	447	90	9	0
955	450	91	9	1
962	454	92	9	2
970	458	93	9	3
978	462	94	9	4
986	465	95	9	5
994	469	96	9	6
1002	473	97	9	7
1009	476	98	9	8
1017	480	99	9	9
1025	484	100	0	0



Unit Setup

Chart 14- LSxF 08SQ ECM CFM Table

LSxF 08SQ

Motor Min CFM: 100
 Motor Max CFM: 460

CFM	L/sec	% Setting	TENS Switch	UNITS Switch
100	47	1	0	1
103	49	2	0	2
107	50	3	0	3
111	52	4	0	4
114	54	5	0	5
118	56	6	0	6
121	57	7	0	7
125	59	8	0	8
129	61	9	0	9
132	62	10	1	0
136	64	11	1	1
140	66	12	1	2
143	68	13	1	3
147	69	14	1	4
151	71	15	1	5
154	73	16	1	6
158	75	17	1	7
162	76	18	1	8
165	78	19	1	9
169	80	20	2	0
172	81	21	2	1
176	83	22	2	2
180	85	23	2	3
183	87	24	2	4
187	88	25	2	5
191	90	26	2	6
194	92	27	2	7
198	93	28	2	8
202	95	29	2	9
205	97	30	3	0
209	99	31	3	1
212	100	32	3	2
216	102	33	3	3
220	104	34	3	4
223	105	35	3	5
227	107	36	3	6
231	109	37	3	7
234	111	38	3	8
238	112	39	3	9
242	114	40	4	0
245	116	41	4	1
249	117	42	4	2
253	119	43	4	3
256	121	44	4	4
260	123	45	4	5
263	124	46	4	6
267	126	47	4	7
271	128	48	4	8
274	129	49	4	9
278	131	50	5	0

CFM	L/sec	% Settings	TENS Switch	UNITS Switch
282	133	51	5	1
285	135	52	5	2
289	136	53	5	3
293	138	54	5	4
296	140	55	5	5
300	142	56	5	6
303	143	57	5	7
307	145	58	5	8
311	147	59	5	9
314	148	60	6	0
318	150	61	6	1
322	152	62	6	2
325	154	63	6	3
329	155	64	6	4
333	157	65	6	5
336	159	66	6	6
340	160	67	6	7
344	162	68	6	8
347	164	69	6	9
351	166	70	7	0
354	167	71	7	1
358	169	72	7	2
362	171	73	7	3
365	172	74	7	4
369	174	75	7	5
373	176	76	7	6
376	178	77	7	7
380	179	78	7	8
384	181	79	7	9
387	183	80	8	0
391	184	81	8	1
394	186	82	8	2
398	188	83	8	3
402	190	84	8	4
405	191	85	8	5
409	193	86	8	6
413	195	87	8	7
416	196	88	8	8
420	198	89	8	9
424	200	90	9	0
427	202	91	9	1
431	203	92	9	2
435	205	93	9	3
438	207	94	9	4
442	209	95	9	5
445	210	96	9	6
449	212	97	9	7
453	214	98	9	8
456	215	99	9	9
460	217	100	0	0

Unit Setup

Chart 15– LSxF 09SQ ECM CFM Table

LSxF 09SQ

Motor Min CFM: 240

Motor Max CFM: 950

CFM	% L/sec	TENS Setting	UNITS Switch	Switch
240	113	1	0	1
247	117	2	0	2
255	120	3	0	3
262	123	4	0	4
269	127	5	0	5
276	130	6	0	6
283	134	7	0	7
290	137	8	0	8
298	140	9	0	9
305	144	10	1	0
312	147	11	1	1
319	151	12	1	2
326	154	13	1	3
333	157	14	1	4
341	161	15	1	5
348	164	16	1	6
355	167	17	1	7
362	171	18	1	8
369	174	19	1	9
376	178	20	2	0
384	181	21	2	1
391	184	22	2	2
398	188	23	2	3
405	191	24	2	4
412	195	25	2	5
419	198	26	2	6
427	201	27	2	7
434	205	28	2	8
441	208	29	2	9
448	211	30	3	0
455	215	31	3	1
462	218	32	3	2
470	222	33	3	3
477	225	34	3	4
484	228	35	3	5
491	232	36	3	6
498	235	37	3	7
505	239	38	3	8
513	242	39	3	9
520	245	40	4	0
527	249	41	4	1
534	252	42	4	2
541	255	43	4	3
548	259	44	4	4
556	262	45	4	5
563	266	46	4	6
570	269	47	4	7
577	272	48	4	8
584	276	49	4	9
592	279	50	5	0

CFM	L/sec	% Setting	TENS Switch	UNITS Switch
599	283	51	5	1
606	286	52	5	2
613	289	53	5	3
620	293	54	5	4
627	296	55	5	5
635	299	56	5	6
642	303	57	5	7
649	306	58	5	8
656	310	59	5	9
663	313	60	6	0
670	316	61	6	1
678	320	62	6	2
685	323	63	6	3
692	327	64	6	4
699	330	65	6	5
706	333	66	6	6
713	337	67	6	7
721	340	68	6	8
728	343	69	6	9
735	347	70	7	0
742	350	71	7	1
749	354	72	7	2
756	357	73	7	3
764	360	74	7	4
771	364	75	7	5
778	367	76	7	6
785	371	77	7	7
792	374	78	7	8
799	377	79	7	9
807	381	80	8	0
814	384	81	8	1
821	387	82	8	2
828	391	83	8	3
835	394	84	8	4
842	398	85	8	5
850	401	86	8	6
857	404	87	8	7
864	408	88	8	8
871	411	89	8	9
878	415	90	9	0
885	418	91	9	1
893	421	92	9	2
900	425	93	9	3
907	428	94	9	4
914	431	95	9	5
921	435	96	9	6
928	438	97	9	7
936	442	98	9	8
943	445	99	9	9
950	448	100	0	0



Unit Setup

Chart 15- LSxF 10SQ ECM CFM Table

LSxF 10SQ

Motor Min CFM: 400
 Motor Max CFM: 1800

CFM	L/sec	% Setting	TENS Switch	UNITS Switch	CFM	L/sec	% Setting	TENS Switch	UNITS Switch
400	189	1	0	1	1107	523	51	5	1
414	196	2	0	2	1121	529	52	5	2
428	202	3	0	3	1135	536	53	5	3
443	209	4	0	4	1150	543	54	5	4
457	216	5	0	5	1164	549	55	5	5
471	222	6	0	6	1178	556	56	5	6
485	229	7	0	7	1192	563	57	5	7
499	236	8	0	8	1206	569	58	5	8
513	242	9	0	9	1220	576	59	5	9
527	249	10	1	0	1234	583	60	6	0
542	256	11	1	1	1249	589	61	6	1
556	262	12	1	2	1263	596	62	6	2
570	269	13	1	3	1277	603	63	6	3
584	276	14	1	4	1291	609	64	6	4
598	282	15	1	5	1305	616	65	6	5
612	289	16	1	6	1319	623	66	6	6
626	296	17	1	7	1333	629	67	6	7
641	302	18	1	8	1348	636	68	6	8
655	309	19	1	9	1362	643	69	6	9
669	316	20	2	0	1376	649	70	7	0
683	322	21	2	1	1390	656	71	7	1
697	329	22	2	2	1404	663	72	7	2
711	336	23	2	3	1418	669	73	7	3
725	342	24	2	4	1432	676	74	7	4
740	349	25	2	5	1447	683	75	7	5
754	356	26	2	6	1461	689	76	7	6
768	362	27	2	7	1475	696	77	7	7
782	369	28	2	8	1489	703	78	7	8
796	376	29	2	9	1503	709	79	7	9
810	382	30	3	0	1517	716	80	8	0
824	389	31	3	1	1531	723	81	8	1
838	396	32	3	2	1545	729	82	8	2
853	402	33	3	3	1560	736	83	8	3
867	409	34	3	4	1574	743	84	8	4
881	416	35	3	5	1588	749	85	8	5
895	422	36	3	6	1602	756	86	8	6
909	429	37	3	7	1616	763	87	8	7
923	436	38	3	8	1630	769	88	8	8
937	442	39	3	9	1644	776	89	8	9
952	449	40	4	0	1659	783	90	9	0
966	456	41	4	1	1673	789	91	9	1
980	462	42	4	2	1687	796	92	9	2
994	469	43	4	3	1701	803	93	9	3
1008	476	44	4	4	1715	809	94	9	4
1022	482	45	4	5	1729	816	95	9	5
1036	489	46	4	6	1743	823	96	9	6
1051	496	47	4	7	1758	829	97	9	7
1065	502	48	4	8	1772	836	98	9	8
1079	509	49	4	9	1786	843	99	9	9
1093	516	50	5	0	1800	850	100	0	0

Wiring Diagrams

Figure 19 – Single-Duct Units (Electronic or DDC/UCM)

SINGLE DUCT UNITS - ELECTRONIC OR DDC/UCM - HEATER TERMINALS - TYPICAL OF SINGLE PHASE VOLTAGES

SINGLE PHASE LINE VOLTAGES	STAGES
208	1
240	2
277	3
347	
480	

HEATER CONTACTORS
Magnetic Contactors (MAGN)
Mercury Contactors (MERC)

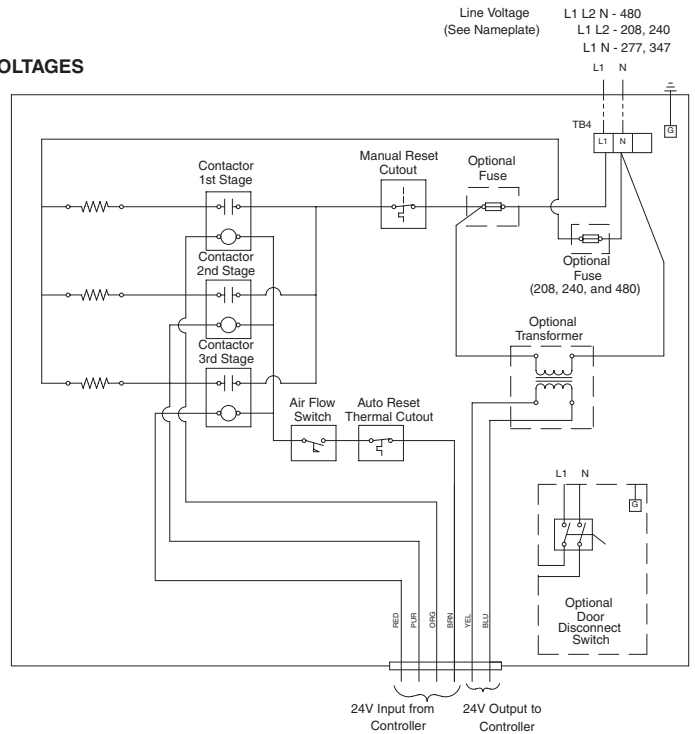

SINGLE DUCT UNITS - ELECTRONIC OR DDC/UCM - HEATER TERMINALS - TYPICAL OF THREE PHASE VOLTAGES

THREE PHASE LINE VOLTAGES	STAGES
208	1
480	2
575	3

HEATER CONTACTORS
Magnetic Contactors (MAGN)
Mercury Contactors (MERC)

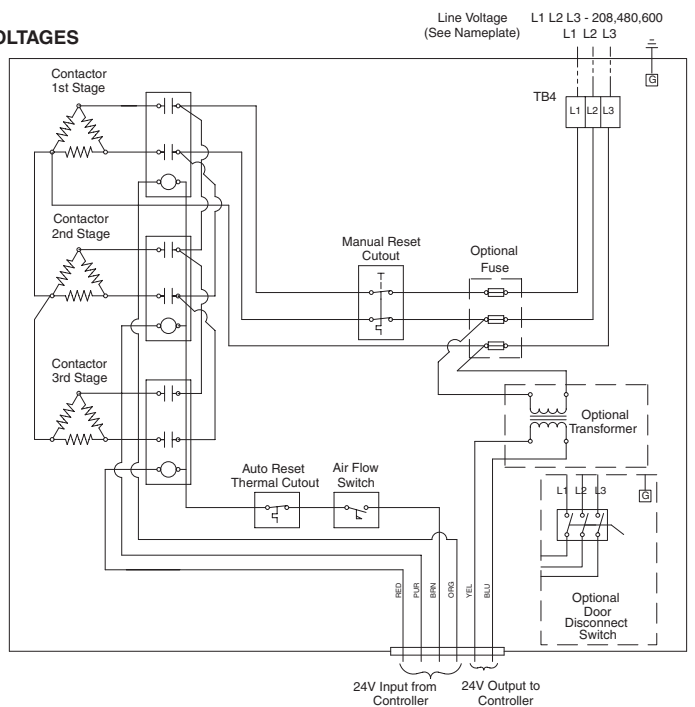

- Notes:
- FACTORY INSTALLED
 - 1. - - - - - FIELD INSTALLED
 - - - - - OPTIONAL
 - 2. Actual heater wiring diagrams are supplied with each unit (3-stage shown).
 - 3. Load carrying P.E. Switches or Contactors are supplied depending upon amp drawn.
 - 4. Air Flow Switch, Auto Reset Thermal Cutout and Manual Reset Cutout are provided as standard.
 - 5. Heater Line Fuses, Transformers, and Door Interlocking Disconnect are optional.
 - 6. If transformer is not ordered, a separate 24-volt power supply is required for operation of unit controls.

Wiring Diagrams

Figure 20 – Single-Duct Units (Pneumatic Controls)

SINGLE DUCT UNITS - PNEUMATIC CONTROL - HEATER TERMINAL - TYPICAL OF SINGLE PHASE VOLTAGES

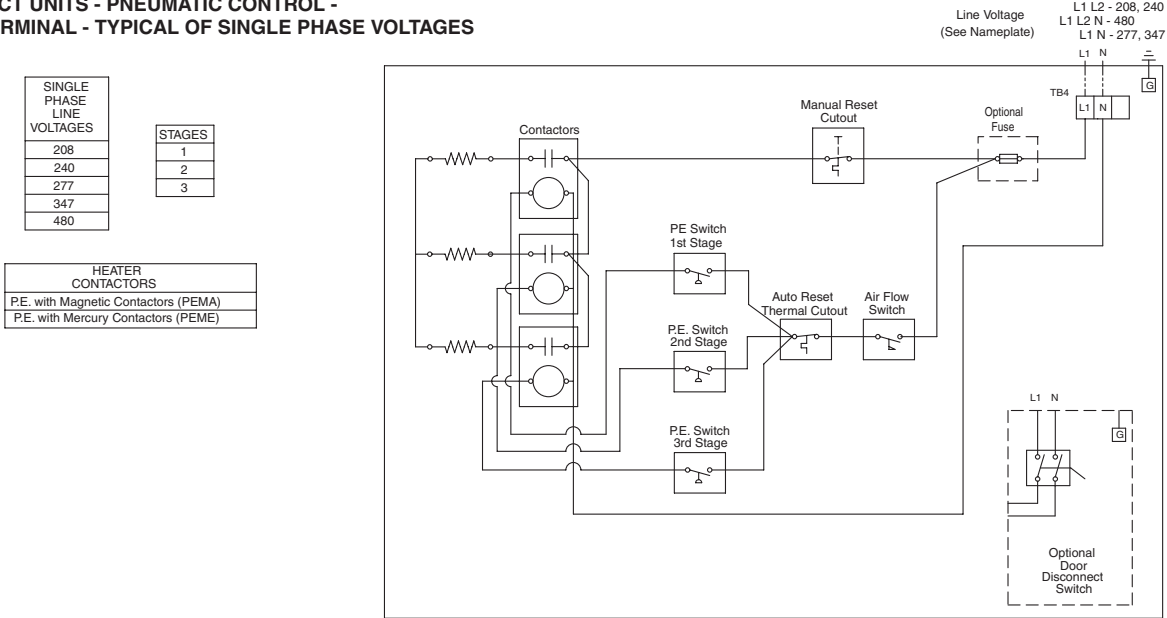

SINGLE DUCT UNITS - PNEUMATIC CONTROL - HEATER TERMINAL - TYPICAL OF THREE PHASE VOLTAGES

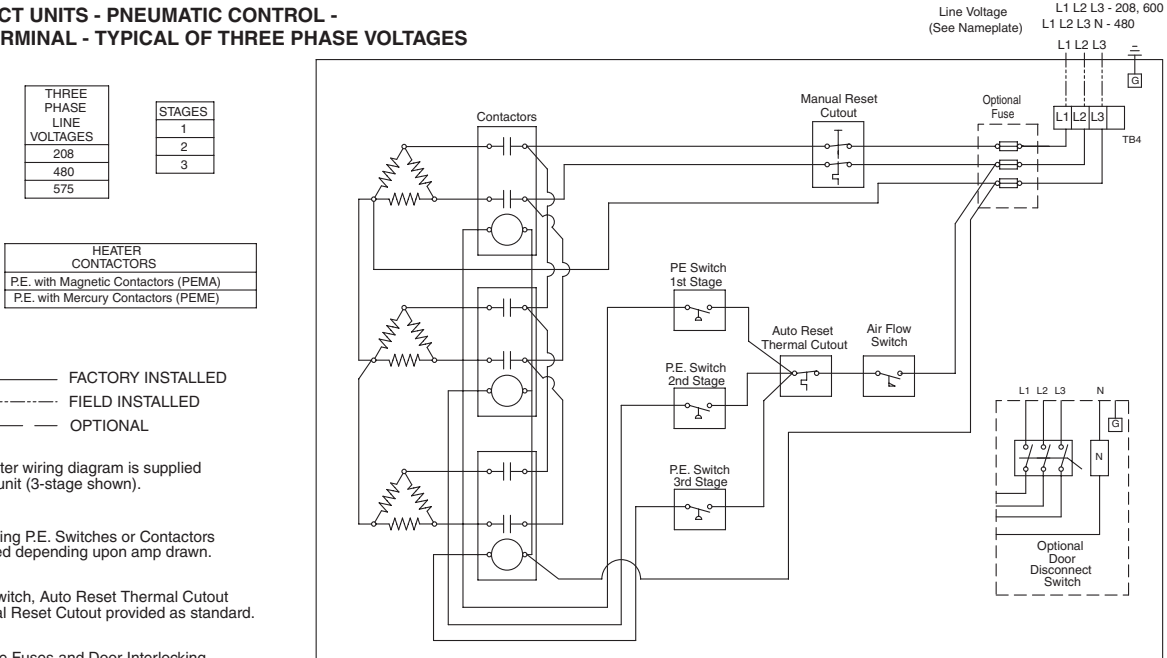

NOTE:

- FACTORY INSTALLED
 - - - - - FIELD INSTALLED
 - - - - - OPTIONAL
- Actual heater wiring diagram is supplied with each unit (3-stage shown).
- Load carrying P.E. Switches or Contactors are supplied depending upon amp drawn.
- Air Flow Switch, Auto Reset Thermal Cutout and Manual Reset Cutout provided as standard.
- Heater Line Fuses and Door Interlocking Disconnect are optional.

Wiring Diagrams

Figure 21 – Fan-Powered Units (Electronic or DDC/UCM)

FAN-POWERED UNITS - ELECTRONIC OR DDC/UCM - HEATER TERMINALS - TYPICAL OF SINGLE PHASE VOLTAGES

SINGLE PHASE LINE VOLTAGES	STAGES
208	1
240	2
277	
347	
480	

HEATER CONTACTORS
Magnetic Contactors (MAGN)
Mercury Contactors (MERC)

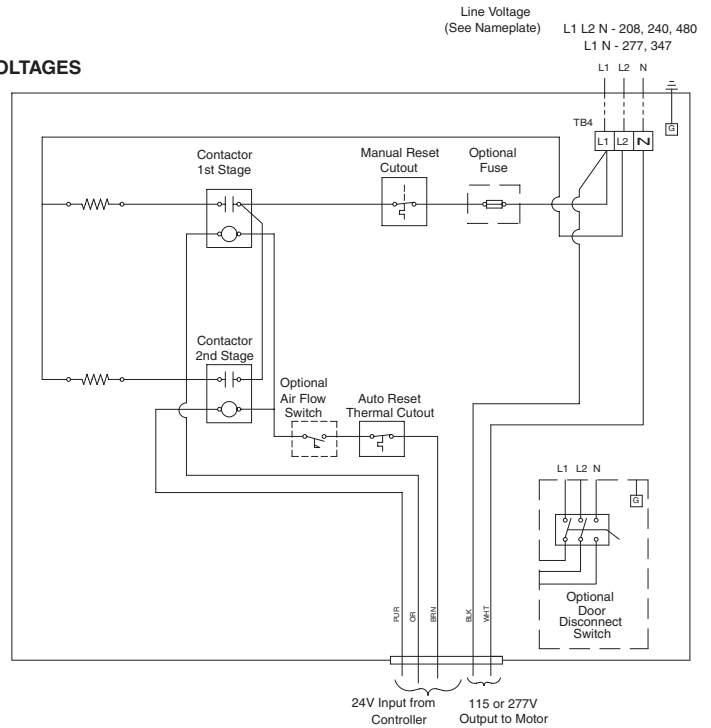

FAN-POWERED UNITS - ELECTRONIC OR DDC/UCM - HEATER TERMINALS - TYPICAL OF THREE PHASE VOLTAGES

THREE PHASE LINE VOLTAGES	STAGES
208	1
480	2
575	

HEATER CONTACTORS
Magnetic Contactors (MAGN)
Mercury Contactors (MERC)

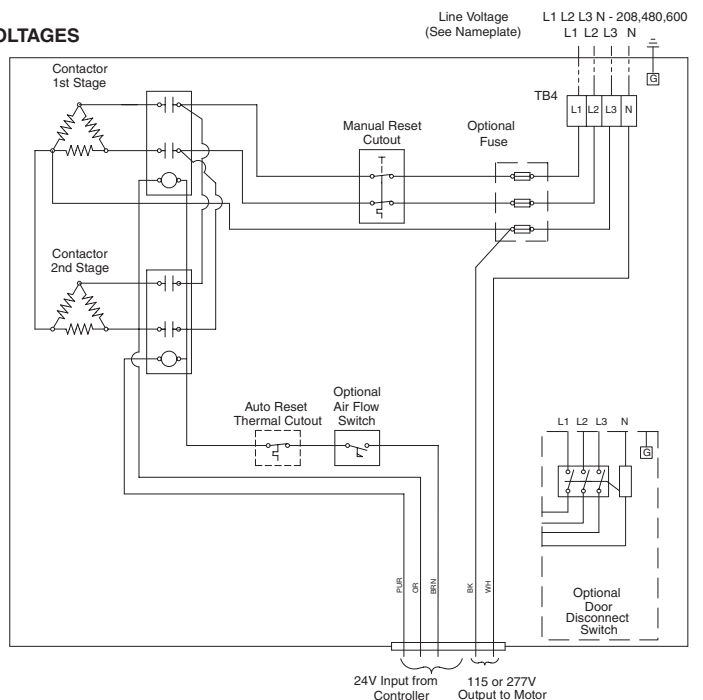

- Notes:
- _____ FACTORY INSTALLED
 - 1. - - - - - FIELD INSTALLED
 - 2. - - - - - OPTIONAL
2. Actual heater wiring diagrams are supplied with each unit (2-stage shown).
 3. Load carrying P.E. Switches or Contactors are supplied depending upon amp drawn.
 4. Auto Reset Thermal Cutout and Manual Reset Cutout are provided as standard.
 5. Heater Line Fuses, Airflow Switch, and Door Interlocking Disconnect are optional.

Wiring Diagrams

Figure 22 – Fan-Powered Units (Pneumatic Controls)

FAN-POWERED UNITS - PNEUMATIC CONTROL - HEATER TERMINAL - TYPICAL OF SINGLE PHASE VOLTAGES

SINGLE PHASE LINE VOLTAGES	STAGES
208	1
240	2
277	3
347	
480	

HEATER CONTACTORS
P.E. with Magnetic Contactors (PEMA)
P.E. with Mercury Contactors (PEME)

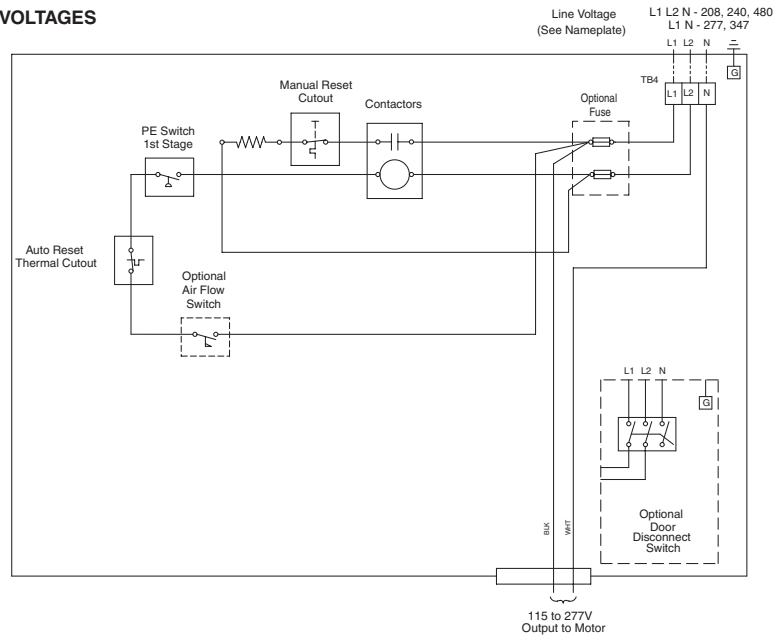

FAN-POWERED UNITS - PNEUMATIC CONTROL - HEATER TERMINAL - TYPICAL OF THREE PHASE VOLTAGES

THREE PHASE LINE VOLTAGES	STAGES
208	1
480	2
575	3

HEATER CONTACTORS
P.E. with Magnetic Contactors (PEMA)
P.E. with Mercury Contactors (PEME)

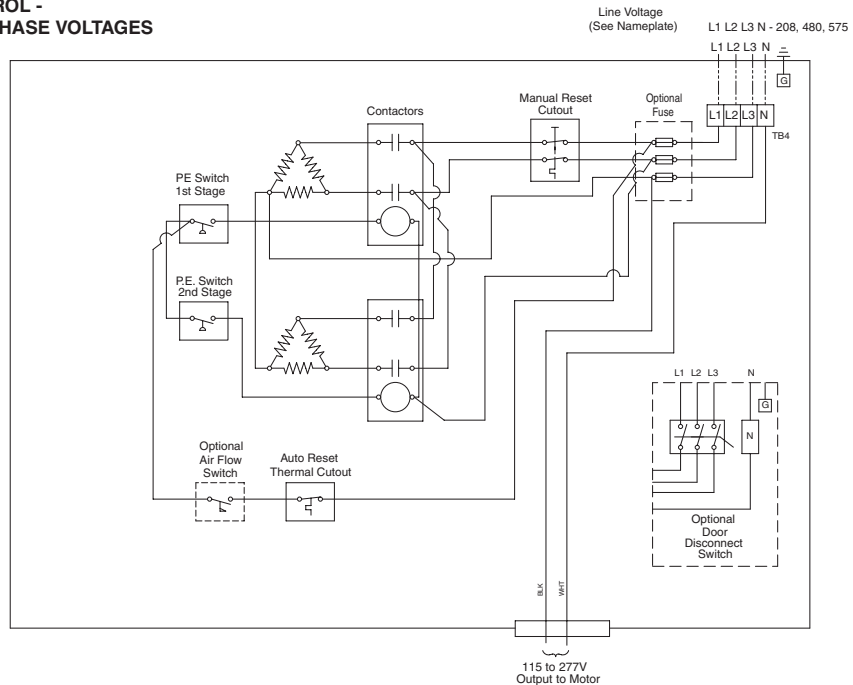

- NOTE:
- FACTORY INSTALLED
 - - - - - FIELD INSTALLED
 - - - - - OPTIONAL
 - Actual heater wiring diagram is supplied with each unit (1 and 2-stage shown).
 - Load carrying P.E. Switches or Contactors are supplied depending upon amp drawn.
 - Auto Reset Thermal Cutout and Manual Reset Cutout provided as standard.
 - Heater Line Fuses, Door Interlocking Disconnect, and Airflow Switch are optional.

Wiring Diagrams

Figure 23 – Fan-Powered Control Boxes

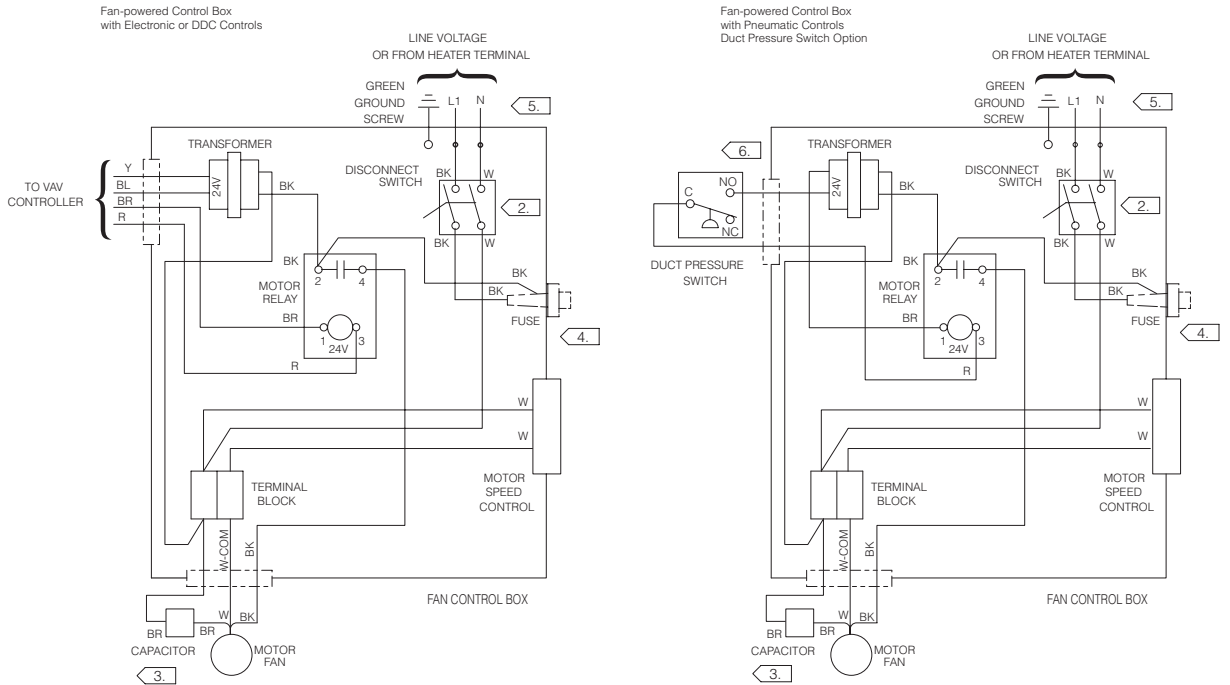

⚠ WARNING
 HAZARDOUS VOLTAGE!
 DISCONNECT, LOCK OUT AND TAG ALL ELECTRIC POWER INCLUDING REMOTE DISCONNECTS BEFORE SERVICING.
 DISCHARGE MOTOR START/RUN CAPACITORS BEFORE SERVICING.
 FAILURE TO DISCONNECT POWER BEFORE SERVICING CAN CAUSE SEVERE PERSONAL INJURY OR DEATH.

⚠ CAUTION
 USE COPPER CONDUCTORS ONLY!
 UNIT TERMINALS ARE NOT DESIGNED TO ACCEPT OTHER TYPES OF CONDUCTORS.
 FAILURE TO DO SO MAY CAUSE DAMAGE TO THE EQUIPMENT.

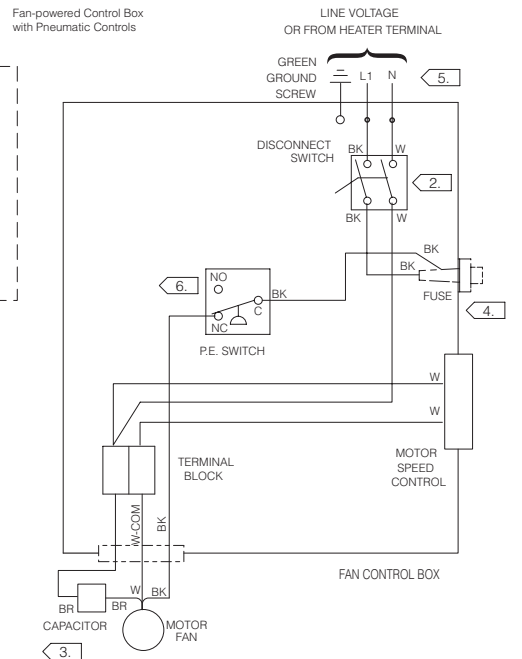
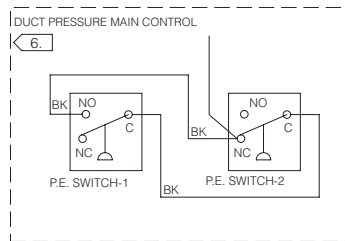

- NOTES:
- 1. ————— FACTORY INSTALLED
 - - - - - BY OTHERS
 - · - · - · OPTIONAL OR ALTERNATE CIRCUITRY
- Ⓐ DISCONNECT SWITCH, FUSE, & SCR ARE LOCATED EXTERNAL TO CONTROL BOX.
 - Ⓑ CAPACITOR IS INSTALLED ON FAN HOUSING.
 - Ⓒ FUSE IS OPTIONAL.
 - Ⓓ DETERMINED BY MOTOR VOLTAGE ON ORDER. VOLTAGE FOUND ON UNIT NAMEPLATE.
 - Ⓔ FOR SERIES FAN POWERED TERMINAL UNITS ONLY.

Wiring Diagrams

Figure 24 – Fan-Powered Units with ECM

Fan-powered Control Box w/ ECM with Electronic or DDC Controls
(Depending on the size of the unit, the ECM board may or may not be located in the fan control box.)

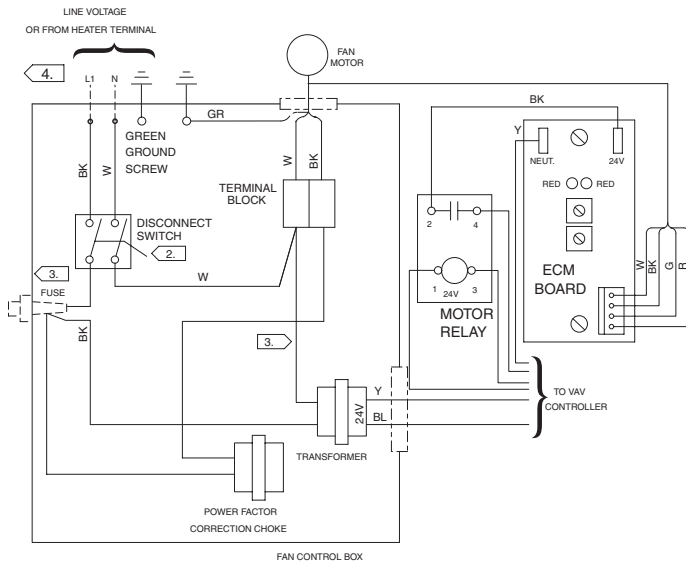

Fan-powered Control Box w/ ECM with Pneumatic Controls
Duct Pressure Switch Option

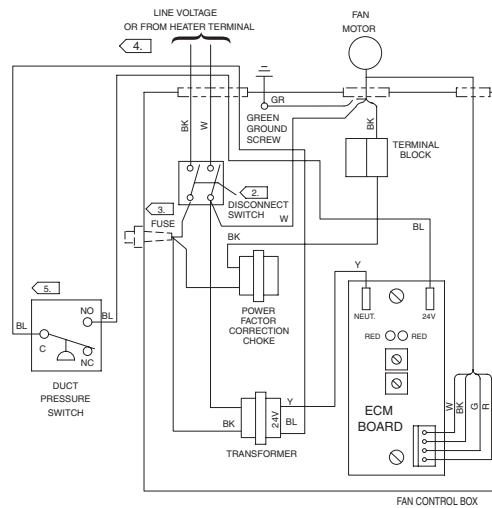

⚠ WARNING
HAZARDOUS VOLTAGE!
DISCONNECT, LOCK OUT AND TAG ALL ELECTRIC POWER INCLUDING REMOTE DISCONNECTS BEFORE SERVICING.
DISCHARGE MOTOR START/RUN CAPACITORS BEFORE SERVICING.
FAILURE TO DISCONNECT POWER BEFORE SERVICING CAN CAUSE SEVERE PERSONAL INJURY OR DEATH.

⚠ CAUTION
USE COPPER CONDUCTORS ONLY!
UNIT TERMINALS ARE NOT DESIGNED TO ACCEPT OTHER TYPES OF CONDUCTORS.
FAILURE TO DO SO MAY CAUSE DAMAGE TO THE EQUIPMENT.

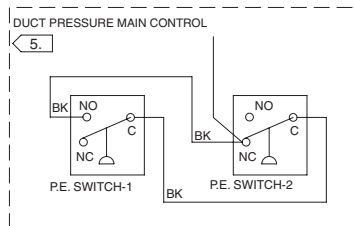

Fan-powered Control Box with Pneumatic Controls

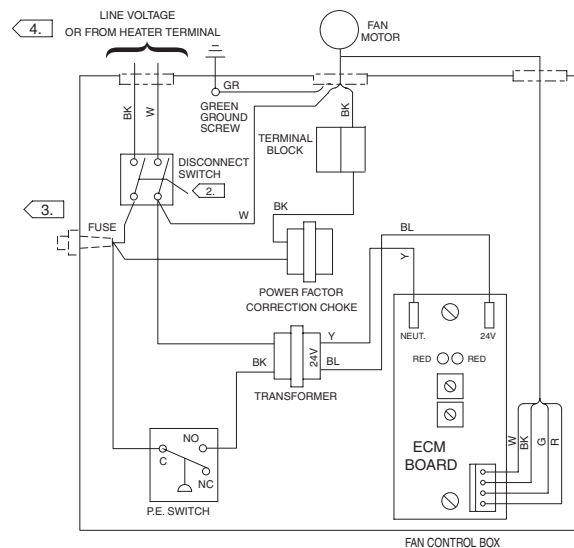

NOTES:

- 1. _____ FACTORY INSTALLED
- - - - - BY OTHERS
- · - · - · OPTIONAL OR ALTERNATE CIRCUITRY
- 2. DISCONNECT SWITCH, FUSE, & SCR ARE LOCATED EXTERNAL TO CONTROL BOX.
- 3. FUSE IS OPTIONAL.
- 4. DETERMINED BY MOTOR VOLTAGE ON ORDER. VOLTAGE FOUND ON UNIT NAMEPLATE.
- 5. FOR SERIES FAN POWERED TERMINAL UNITS ONLY.

Wiring Diagrams

Figure 26 – Fan-Powered Low-Height Units with ECM

Fan-Powered Low-Height Control Box w/ ECM with Electronic or DDC Controls
(Depending on the size of the unit, the ECM board may or may not be located in the fan control box.)

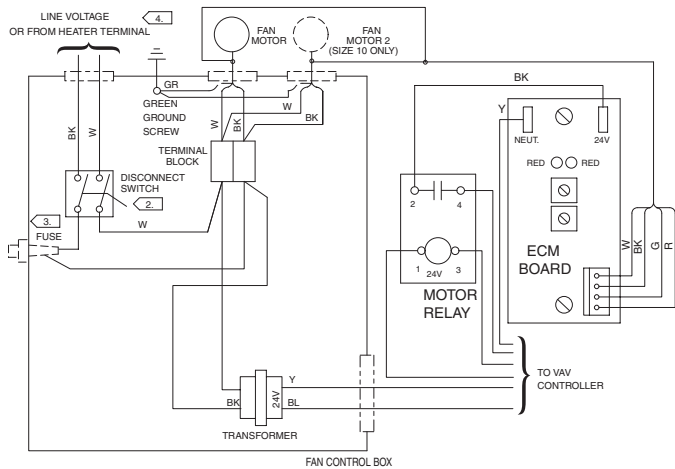

Fan-Powered Low-Height Control Box w/ ECM with Pneumatic Controls Duct Pressure Switch Option

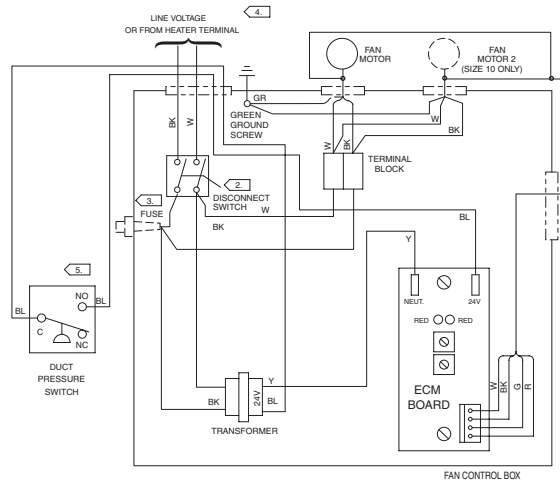

⚠ WARNING
HAZARDOUS VOLTAGE!
DISCONNECT, LOCK OUT AND TAG ALL ELECTRIC POWER INCLUDING REMOTE DISCONNECTS BEFORE SERVICING.
DISCHARGE MOTOR START/RUN CAPACITORS BEFORE SERVICING.
FAILURE TO DISCONNECT POWER BEFORE SERVICING CAN CAUSE SEVERE PERSONAL INJURY OR DEATH.

⚠ CAUTION
USE COPPER CONDUCTORS ONLY!
UNIT TERMINALS ARE NOT DESIGNED TO ACCEPT OTHER TYPES OF CONDUCTORS.
FAILURE TO DO SO MAY CAUSE DAMAGE TO THE EQUIPMENT.

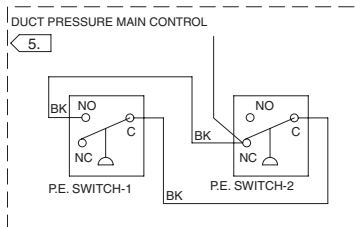

NOTES:

- 1. ———— FACTORY INSTALLED
- - - - - BY OTHERS
- · - · - OPTIONAL OR ALTERNATE CIRCUITRY
- 2. DISCONNECT SWITCH, FUSE, & SCR ARE LOCATED EXTERNAL TO CONTROL BOX.
- 3. FUSE IS OPTIONAL.
- 4. DETERMINED BY MOTOR VOLTAGE ON ORDER. VOLTAGE FOUND ON UNIT NAMEPLATE.
- 5. FOR SERIES FAN POWERED TERMINAL UNITS ONLY.

Fan-Powered Low-Height Control Box w/ ECM with Pneumatic Controls

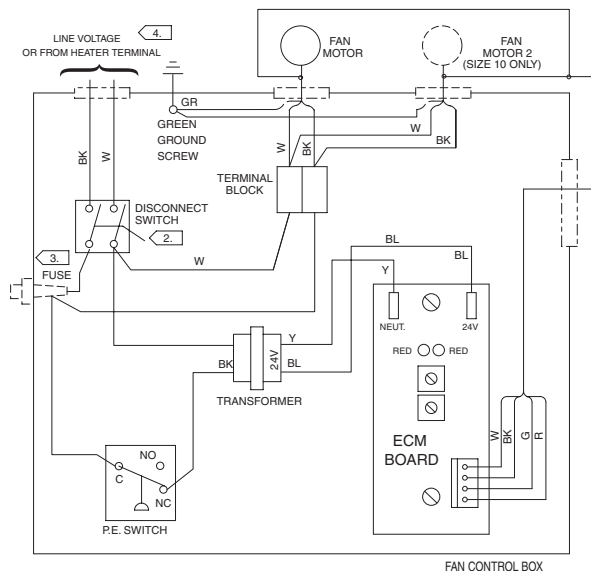

Maintenance

Periodic maintenance of the VariTrane product is minimal, but necessary for efficient operation. Routine maintenance consists of inspecting/replacing the air filters of the fan-powered terminals.

Motors

Both the PSC (permanent split capacitor) and the ECM (Electrically Commutated Motor) require no lubrication during its normal life of operation.

Fan Wheel:

Periodically, the fan wheel should be inspected for dirt or debris and cleaned as necessary.

Filter

The filter on fan-powered terminals will need to be inspected/replaced routinely depending on the environmental conditions of the plenum.

Water Coil

Water coils should be inspected and the fins should be cleaned periodically.

Water coils have been provided with an access panel as standard to assist with inspection and cleaning.

Fan Motor Replacement

⚠ WARNING

Hazardous Voltage w/Capacitors!

Disconnect all electric power, including remote disconnects and discharge all motor start/run capacitors before servicing. Follow proper lockout/tagout procedures to ensure the power cannot be inadvertently energized. Verify with an appropriate voltmeter that all capacitors have discharged. Failure to disconnect power and discharge capacitors before servicing could result in death or serious injury.

⚠ WARNING

Rotating Components!

Disconnect all electric power, including remote disconnects before servicing. Follow proper lockout/tagout procedures to ensure the power cannot be inadvertently energized. Failure to disconnect power before servicing could result in death or serious injury.

Figure 27 – Standard Motor Removal

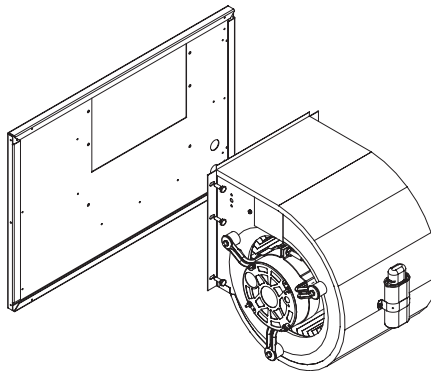

Standard height fan-powered series and parallel fan motors are replaceable through the filter opening and the standard sliding side access panel. To access the fan motor, the fan housing must be detached by removing the mounting bolts that hold the housing to the fan board. Removing the entire housing allows the fan motor, fan housing, and fan wheel to be re-aligned on a workbench or floor and prevent any possible fan wheel rubbing that may occur. Removing the housing will provide access to the motor shaft set screw that holds the fan wheel to the motor shaft.

The low-height fan assembly was designed with an inlet ring that assists with removal of the fan motor. To access the fan motor assembly, the bottom panel must be removed. The inlet ring is held in place by six bolts and three motor mount bolts. Remove these bolts and the motor and fan wheel will come out of the fan housing.

Figure 28 – Low-Height Motor Removal

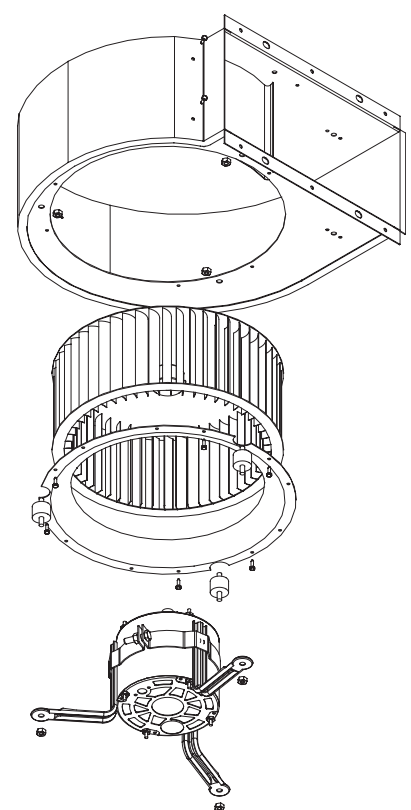

Installation of Diffusers

General

All units must be installed upright and level as indicated by the arrow on the side of the units. Return air slots should be placed perpendicular and offset to the slot diffusers to avoid short-circuiting of air distribution patterns.

Place the unit in its approximate final position and check that it is upright and level. For **single-slot units**, engage the back of the diffuser over the t-bar with an edge and both ends resting on the t-bar. For **double-slot units**, slide the unit over the t-bar. For **center-notch units**, place diffuser over the t-bar, straddling it across a t-bar and resting on the units ends.

If the unit has a fire damper, make sure that the damper is still fully open. Diffuser discharge must always be flush with the ceiling tiles to assure the proper airflow (Coanda effect).

Diffusers require specific installation information when mounting to a desired ceiling type. Select the ceiling type that closely matches the job site application and use the following procedures.

T-Bar Ceiling

Finish installation of the diffuser in t-bar ceiling. (See Figure 29.) Follow these procedures before the ceiling construction is completed.

1. Position the diffuser at each end resting directly on the structural t-bar for support and the t-bar fitting into the channel provided at the unit discharge air throw.
2. A ceiling tile support flange is provided on each side of the discharge slot of the unit. Trim ceiling tile approximately 1½ inches each to allow for width of discharge slot. For revealed edge ceilings, tile must be cut in a "Z" pattern.
3. Install ceiling tiles in usual manner with cut edges resting on the flanges of the air slot.

Figure 29 – Diffuser Installation in T-Bar Ceiling

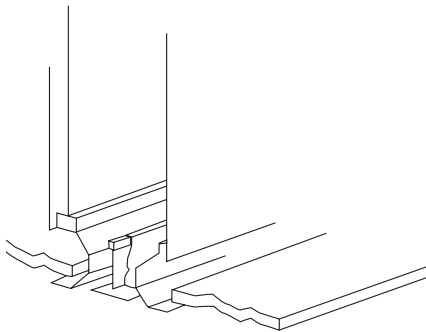

Concealed Spline Ceiling

Follow these procedures to finish installation of control and satellite diffusers and concealed spline for suspension ceilings before completing the ceiling construction (Figure 30).

Place the units in their approximate final positions. If using the trim angle diffuser, its slots must be even with the spline level. If applying the trim accessory, the bottom of the diffuser must be level with the finished ceiling.

If installing the trim accessory, insert the trim into the ceiling opening from below and engage the diffuser slot to the trim t-bar structure. With bottom flange of trim accessory against the ceiling, and using the pre-drilled holes in the flange as a guide, drill holes in the flange of the diffuser. Join the diffuser and trim accessory with self-taping sheet metal.

Figure 30 – Diffuser with Trim Accessory Installation in Concealed Spline Ceiling

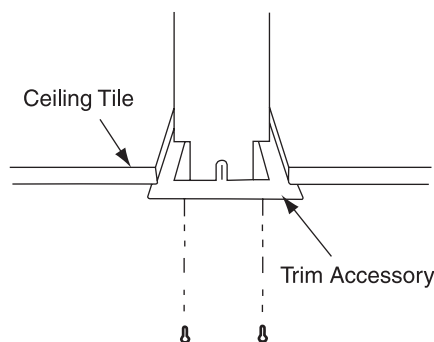

Drywall/Plaster Ceiling

Finish installation of diffusers in plaster ceiling. Follow these procedures before completing the ceiling construction (Figure 31).

1. Suspend the units above the intended ceiling level and their approximate horizontal positions and finish running flexible ductwork.
2. After drywall and/or plaster is installed, cut openings to receive the diffuser air outlets. Also, allow for access openings to complete installation and service of the unit.
3. Slide the trim accessory up and into the ceiling opening. Using the rim accessory as a template, drill four guide holes in the lip of the diffuser slot. Lower the unit onto the trim frame and attach with the sheet metal screws.

Note: *The bottom of the throat section must be parallel to the ceilings for proper air distribution.*

CAUTION

Equipment Damage!

Do not install trim frame into ceiling using screws. When diffuser is placed on the trim frames, it will pull out.

Figure 31 – Diffuser with Trim Accessory Installation in Plaster Ceiling

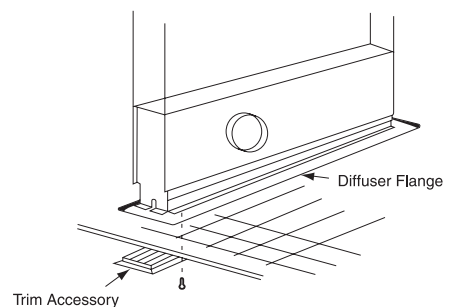

Plaster trim frame attaches with 2–4 tension clips on the side of the diffuser.

Notes



TRANE[®]

Trane
An American Standard Company
www.trane.com

*For more information contact
your local district office or
e-mail us at comfort@trane.com*

Literature Order Number	VAV-SVN01E-EN
File Number	SL-TD-000-VAV-SVN01E-EN-0606
Supersedes	SL-TD-000-VAV-SVN01D-EN-0905
Stocking Location	Inland

Trane has a policy of continuous product and product data improvement and reserves the right to change design and specifications without notice. Only qualified technicians should perform the installation and servicing of equipment referred to in this publication.